

GENERAL INFORMATION

POWER-STUD® + SD1

Wedge Expansion Anchor

PRODUCT DESCRIPTION

The Power-Stud+ SD1 anchor is a fully threaded, torque-controlled, wedge expansion anchor designed for consistent performance in cracked and uncracked concrete. Suitable base materials include normal-weight concrete, lightweight concrete, concrete-filled steel deck and grouted masonry. Anchors manufactured with a zinc plated carbon steel body, expansion clip, nut and washer.

GENERAL APPLICATIONS AND USES

- Structural connections, i.e., beam and column anchorage
- Safety-related attachments
- Barriers and guards
- Fencing and railing
- Mezzanines and racking
- Tension zone applications, i.e., cable trays and strut, pipe supports, fire sprinklers
- Trapeze / overhead utilities
- Ledgers, angles and brackets
- Equipment anchorage
- Wind and seismic loading (SDC A - F)

FEATURES AND BENEFITS

- + Consistent performance in high and low strength concrete
- + Nominal drill bit size is the same as the anchor diameter
- + Anchor can be installed through standard fixture holes
- + Length ID code and identifying marking stamped on head of each anchor
- + Anchor design allows for follow-up expansion after setting under tensile loading
- + Power-Stud+ SD1 optionally available as made in USA at time of publication; product certifications available by request (anchors@DEWALT.com)

APPROVALS AND LISTINGS

- International Code Council, Evaluation Service (ICC-ES), ESR-2818 for cracked and uncracked concrete
- International Code Council, Evaluation Service (ICC-ES), ESR-2966 for masonry
- Code compliant with the 2024 IBC/IRC, 2021 IBC/IRC, 2018 IBC/IRC, and 2015 IBC/IRC
- Tested in accordance with ACI 355.2/ASTM E488 and ICC-ES AC193 for use in structural concrete under the design provisions of ACI 318 (-19 or -14) Chapter 17 or ACI 318 Appendix D
- Evaluated and qualified by an accredited independent testing laboratory for recognition in cracked and uncracked concrete including seismic and wind loading (anchor Category 1)
- Tested in accordance with ASTM E488 and ICC-ES AC01 for use in masonry
- City of Los Angeles, LABC and LARC Supplement (within ESR-2818 and ESR-2966)
- Florida Building Code, FBC Supplement including HVHZ (within ESR-2818 and ESR-2966)
- Underwriters Laboratories (UL Listed) - File No. EX1289, see listing for sizes
- FM Approvals (Factory Mutual) – see FM Approval Guide for sizes
- Federal GSA Specification – Meets descriptive characteristics of CID A-A-1923A, Type 4 (formerly Group II, Type 4, Class 1)

GUIDE SPECIFICATIONS

CSI Divisions: 03 16 00 - Concrete Anchors, 04 05 19.16 - Masonry Anchors and 05 05 19 - Post-Installed Concrete Anchors. Expansion anchors shall be Power-Stud+ SD1 as supplied by DEWALT, Towson, MD. Anchors shall be installed in accordance with published instructions and the Authority Having Jurisdiction.

MATERIAL SPECIFICATIONS

Anchor component	Specification
Anchor Body	Medium carbon steel
Hex nut	Carbon steel, ASTM A563, Grade A
Washer	Carbon steel, ASTM F844; meets dimensional requirements of ANSI B18.22.1, Type A Plain
Expansion wedge (clip)	Carbon steel
Plating	Zinc plating according to ASTM B633, SC1 Type III (Fe/Zn 5) Minimum plating requirements for Mild Service Condition.
Anchor body meets or exceeds minimum yield and ultimate strength requirements of ASTM F1554, Grade 55 anchor bolts, ASTM A307 bolts (all grades) and SAE J426, Grade 2 bolts. See Tension Design Information table for yield and ultimate strengths of the anchor body.	

SECTION CONTENTS

General Information..... 1
 Material Specifications 1
 Installation Specifications 2
 Installation Instructions 2
 Performance Data (ASD)..... 3
 Strength Design Information 15
 Design Strength Tables (SD) 21
 Ordering Information..... 22



POWER-STUD+ SD1 ASSEMBLY

THREAD VERSION

- UNC threaded stud

ANCHOR MATERIALS

- Zinc plated carbon steel body with expansion clip, nut and washer

ANCHOR SIZE RANGE (TYP.)

- 1/4" diameter to 1-1/4" diameter

SUITABLE BASE MATERIALS

- Normal-weight concrete
- Lightweight concrete
- Concrete-filled steel deck
- Grouted concrete masonry (CMU)



See ORDERING INFORMATION page for MIUSA Availability

INSTALLATION SPECIFICATIONS

Installation Specifications for Power-Stud+ SD1

Anchor Property/ Setting Information	Notation	Units	Nominal Anchor Diameter								
			1/4	3/8	1/2	5/8	3/4	7/8	1	1-1/4	
Anchor diameter	d_a (d)	in.	0.250	0.375	0.500	0.625	0.750	0.875	1.000	1.250	
Minimum diameter of hole clearance in fixture	d_h	in.	5/16	7/16	9/16	11/16	13/16	1	1-1/8	1-3/8	
Nominal drill bit diameter (ANSI)	d_{bit}	in.	1/4	3/8	1/2	5/8	3/4	7/8	1	1-1/4	
Minimum nominal embedment depth ¹	h_{nom}	in.	1-1/8	1-5/8	2-1/4	2-3/4	3-3/8	3-7/8	4-1/2	5-1/2	
Minimum hole depth	h_o	in.	$h_{nom} + 1/8$		$h_{nom} + 1/4$			$h_{nom} + 3/8$		$h_{nom} + 1/2$	
Minimum concrete thickness	h_{min}	in.	Greater of $1.75h_{nom}$ or 3.25"			1.75 h_{nom} or 4", whichever is greater					
Installation torque	Concrete	T _{inst}	ft.-lbf.	4	20	40	80	110	175	225	375
	Grouted Concrete Masonry (CMU)			4	20	40	50	80	-	-	-
Torque wrench/socket size	-	in.	7/16	9/16	3/4	15/16	1-1/8	1-5/16	1-1/2	1-7/8	
Nut height	-	in.	7/32	21/64	7/16	35/64	41/64	3/4	55/64	1-1/16	
Washer O.D.	-	in.	5/8	13/16	1-1/16	1-5/16	1-15/32	1-3/4	2	2-1/2	

See Strength Design Information for installation specifications in concrete in strict accordance with ICC-ES ESR-2818.
1. See performance data (ASD) load capacities for Power-Stud+ SD1 in normal weight concrete for additional nominal embedment depths.

Power-Stud+ SD1 Anchor Detail

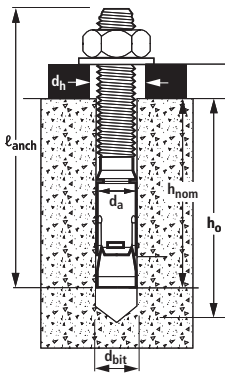

Power-Stud+ SD1 Anchor Assembly

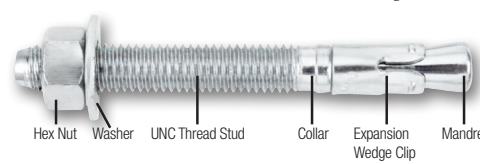

Head Marking



Legend

- Letter Code = Length Identification Mark
- '+' Symbol = Strength Design Compliant Anchor (see ordering information)
- Number 1 = Carbon Steel Body and Expansion Clip ('+' symbol not on 1/4" diameter anchors)

Length Identification

Mark	A	B	C	D	E	F	G	H	I	J	K	L	M	N	O	P	Q	R	S	T
From	1-1/2"	2"	2-1/2"	3"	3-1/2"	4"	4-1/2"	5"	5-1/2"	6"	6-1/2"	7"	7-1/2"	8"	8-1/2"	9"	9-1/2"	10"	11"	12"
Up to but not including	2"	2-1/2"	3"	3-1/2"	4"	4-1/2"	5"	5-1/2"	6"	6-1/2"	7"	7-1/2"	8"	8-1/2"	9"	9-1/2"	10"	11"	12"	13"

Length identification mark indicates overall length of anchor, l_{anch} .

INSTALLATION INSTRUCTIONS

Installation Instructions for Power-Stud+ SD1

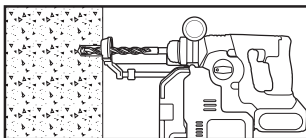

Step 1
Using the proper drill bit size, drill a hole into the base material to the required depth. The tolerances of the drill bit used should meet the requirements of ANSI Standard B212.15.

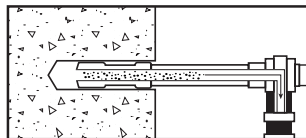

Step 2
Remove the dust and debris from the hole during drilling (e.g. dust extractor, hollow bit) or following drilling (e.g. suction, forced air) to extract loose particles created by drilling.

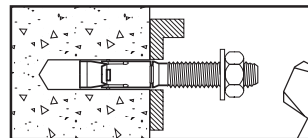

Step 3
Position the washer on the anchor and thread on the nut. If installing through a fixture, drive the anchor through the fixture into the hole. Be sure the anchor is driven to the minimum required embedment depth, h_{nom} .

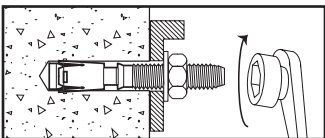

Step 4
Tighten the anchor with a torque wrench by applying the required installation torque, T_{inst} . Note: The threaded stud will draw up during tightening of the nut; the expansion wedge (clip) remains in original position.

Installation Instructions for Power-Stud+ SD1 Tie Wire Version

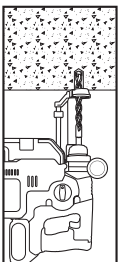

Step 1
Using the proper drill bit size, drill a hole into the base material to the required depth. The tolerances of the drill bit used should meet the requirements of ANSI Standard B212.15.

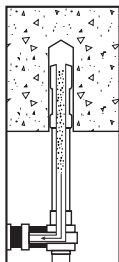

Step 2
Remove the dust and debris from the hole during drilling (e.g. dust extractor) or following drilling (e.g. suction, forced air) to extract loose particles created by drilling.

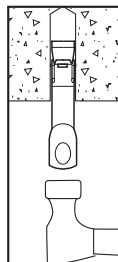

Step 3
Drive the anchor into the hole until the head is firmly seated against the base material. Be sure the anchor is driven to the required embedment depth.

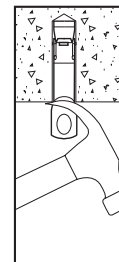

Step 4
Set the anchor with a prying action using a claw hammer.

PERFORMANCE DATA (ASD)

Ultimate Load Capacities for Power-Stud+ SD1 in Normal-Weight Concrete^{1,2}

Nominal Anchor Diameter d in.	Minimum Embedment Depth h _{nom} in. (mm)	Minimum Concrete Compressive Strength							
		f'c = 2,500 psi (17.3 MPa)		f'c = 3,000 psi (20.7 MPa)		f'c = 4,000 psi (27.6 MPa)		f'c = 6,000 psi (41.4 MPa)	
		Tension lbs. (kN)	Shear lbs. (kN)	Tension lbs. (kN)	Shear lbs. (kN)	Tension lbs. (kN)	Shear lbs. (kN)	Tension lbs. (kN)	Shear lbs. (kN)
1/4	1-1/8 (28)	1,320 (5.9)	1,160 (5.2)	1,435 (6.4)	1,255 (5.6)	1,660 (7.4)	1,255 (5.6)	1,660 (7.4)	1,255 (5.6)
	1-3/4 (44)	2,775 (12.4)	1,255 (5.6)	2,775 (12.4)	1,255 (5.6)	2,775 (12.4)	1,255 (5.6)	2,775 (12.4)	1,255 (5.6)
3/8	1-5/8 (41)	2,240 (10.9)	2,320 (10.3)	2,685 (12)	2,540 (11.3)	3,100 (13.8)	2,540 (11.3)	3,100 (13.8)	2,540 (11.3)
	1-7/8 (48)	2,695 (12.0)	2,540 (11.3)	2,955 (13.1)	2,540 (11.3)	3,410 (15.2)	2,540 (11.3)	3,450 (15.3)	2,540 (11.3)
	2-3/8 (60)	3,485 (15.5)	2,540 (11.3)	3,815 (17)	2,540 (11.3)	4,410 (19.6)	2,540 (11.3)	5,400 (24)	2,540 (11.3)
	2-7/8 (73)	5,140 (22.9)	3,810 (16.9)	5,630 (25.0)	3,810 (16.9)	6,505 (28.9)	3,810 (16.9)	6,505 (28.9)	3,810 (16.9)
1/2	2-1/4 (57)	3,800 (16.9)	3,840 (17.1)	4,155 (18.5)	4,195 (18.7)	4,800 (21.4)	4,195 (18.7)	4,800 (21.4)	4,195 (18.7)
	2-1/2 (64)	3,910 (17.4)	4,195 (18.7)	4,285 (19.1)	4,195 (18.7)	4,950 (22)	4,195 (18.7)	6,060 (27)	4,195 (18.7)
	3-3/4 (95)	7,955 (35.4)	4,195 (18.7)	8,715 (38.8)	4,195 (18.7)	10,065 (44.8)	4,195 (18.7)	12,325 (54.8)	4,195 (18.7)
5/8	2-3/4 (70)	4,960 (22.1)	6,220 (27.7)	5,440 (24.3)	6,815 (30.3)	6,285 (28)	6,815 (30.3)	6,285 (28)	6,815 (30.3)
	3-3/8 (86)	6,625 (29.5)	6,815 (30.3)	7,260 (32.3)	6,815 (30.3)	8,380 (37.3)	6,815 (30.3)	10,265 (45.7)	6,815 (30.3)
	4-5/8 (117)	11,260 (50.1)	6,815 (30.3)	12,335 (54.9)	6,815 (30.3)	14,245 (63.4)	6,815 (30.3)	14,465 (65.7)	6,815 (30.3)
3/4	3-3/8 (86)	7,180 (31.9)	11,480 (51.5)	7,860 (32.2)	12,580 (56.0)	9,075 (40.5)	12,580 (56.0)	9,075 (40.5)	12,580 (56.0)
	4 (102)	9,530 (42.4)	12,580 (56.0)	10,440 (46.5)	12,580 (56.0)	12,060 (53.6)	12,580 (56.0)	14,770 (65.7)	12,580 (56.0)
	5-5/8 (143)	17,670 (78.6)	12,580 (56.0)	19,355 (86.1)	12,580 (56.0)	22,350 (99.4)	12,580 (56.0)	25,065 (111.5)	12,580 (56.0)
7/8	3-7/8 (98)	9,120 (40.6)	10,680 (47.5)	10,005 (44.5)	11,690 (52.0)	11,555 (51.4)	11,690 (52.0)	11,555 (51.4)	11,690 (52.0)
	4-1/2 (114)	11,320 (50.4)	11,690 (52.0)	12,405 (55.2)	11,690 (52.0)	15,125 (67.3)	11,690 (52.0)	19,470 (86.6)	11,690 (52.0)
	6-1/4 (159)	15,105 (67.2)	15,795 (70.3)	16,545 (73.6)	17,305 (77.0)	19,105 (85.0)	19,980 (88.9)	19,105 (85.0)	19,980 (88.9)
1	4-1/2 (114)	12,400 (55.2)	19,320 (85.9)	13,580 (60.4)	21,155 (94.1)	15,680 (69.7)	21,155 (94.1)	15,680 (69.7)	21,155 (94.1)
	5-1/2 (140)	16,535 (73.6)	21,155 (94.1)	18,115 (80.6)	21,155 (94.1)	20,915 (93)	21,155 (94.1)	25,615 (114)	21,155 (94.1)
	8 (203)	19,640 (87.4)	21,155 (94.1)	21,530 (95.8)	21,155 (94.1)	24,865 (110.6)	21,155 (94.1)	24,865 (110.6)	21,155 (94.1)
1-1/4	5-1/2 (140)	18,520 (82.5)	26,560 (118.1)	20,275 (90.9)	29,105 (129.4)	23,410 (105.0)	29,105 (129.4)	23,410 (105.0)	29,105 (129.4)
	6-1/2 (165)	22,485 (100.0)	29,105 (129.4)	24,630 (109.6)	29,105 (129.4)	28,440 (126.5)	29,105 (129.4)	37,360 (166.2)	29,105 (129.4)

1. Tabulated load values are for anchors installed in uncracked concrete with no edge or spacing considerations. Concrete compressive strength must be at the specified minimum at the time of installation.
2. Ultimate load capacities must be reduced by a minimum safety factor of 4.0 or greater to determine allowable working loads.

UL Listings and FM Approvals for Supporting Fire Protection Services & Automatic Sprinkler Systems¹

Listing / Approval	Power-Stud+ SD1 Anchors		
	3/8-inch	1/2-inch	5/8-inch
UL Max. Pipe Size	4"	8"	12"
FM Max. Pipe Size	4"	8"	-

Underwriters Laboratories (UL Listed) – File No. EX1289 and VFX17,EX1289
 FM Approvals (Factory Mutual)

1. UL Listing minimum nominal embedment requirements for Power-Stud+ SD1: 2.375-inches for 3/8-inch-diameter anchors; and 2.5 inches for 1/2-inch-diameter anchors; 3.375 inches for 5/8-inch-diameter anchors.

MECHANICAL ANCHORS

POWER-STUD® + SD1
Wedge Expansion Anchor



Allowable Load Capacities for Power-Stud+ SD1 in Normal-Weight Concrete^{1,2,3,4,5}

Nominal Anchor Diameter d (in.)	Minimum Embedment Depth h _{nom} in. (mm)	Minimum Concrete Compressive Strength							
		f'c = 2,500 psi (17.3 MPa)		f'c = 3,000 psi (20.7 MPa)		f'c = 4,000 psi (27.6 MPa)		f'c = 6,000 psi (41.4 MPa)	
		Tension lbs. (kN)	Shear lbs. (kN)	Tension lbs. (kN)	Shear lbs. (kN)	Tension lbs. (kN)	Shear lbs. (kN)	Tension lbs. (kN)	Shear lbs. (kN)
1/4	1-1/8 (28)	330 (1.5)	290 (1.3)	360 (1.6)	315 (1.4)	415 (1.8)	315 (1.4)	415 (1.8)	315 (1.4)
	1-3/4 (44)	695 (3.1)	315 (1.4)	695 (3.1)	315 (1.4)	695 (3.1)	315 (1.4)	695 (3.1)	315 (1.4)
3/8	1-5/8 (41)	610 (2.7)	580 (2.6)	670 (3.0)	635 (2.8)	775 (3.4)	635 (2.8)	775 (3.4)	635 (2.8)
	1-7/8 (48)	675 (3.0)	635 (2.8)	740 (3.3)	635 (2.8)	855 (3.8)	635 (2.8)	865 (3.8)	635 (2.8)
	2-3/8 (60)	870 (3.9)	635 (2.8)	955 (4.2)	635 (2.8)	1,105 (4.9)	635 (2.8)	1,350 (6.0)	635 (2.8)
	2-7/8 (73)	1,285 (5.7)	955 (4.2)	1,410 (6.3)	955 (4.2)	1,625 (7.2)	955 (4.2)	1,625 (7.2)	955 (4.2)
1/2	2-1/4 (57)	950 (4.2)	960 (4.3)	1,040 (4.6)	1,050 (4.7)	1,200 (5.3)	1,050 (4.7)	1,200 (5.3)	1,050 (4.7)
	2-1/2 (64)	980 (4.4)	1,050 (4.7)	1,070 (4.8)	1,050 (4.7)	1,240 (5.5)	1,050 (4.7)	1,515 (6.7)	1,050 (4.7)
	3-3/4 (95)	1,990 (8.9)	1,050 (4.7)	2,180 (9.7)	1,050 (4.7)	2,515 (11.2)	1,050 (4.7)	3,080 (13.7)	1,050 (4.7)
5/8	2-3/4 (70)	1,240 (5.5)	1,555 (6.9)	1,360 (6.0)	1,705 (7.6)	1,570 (7.0)	1,705 (7.6)	1,570 (7.0)	1,705 (7.6)
	3-3/8 (86)	1,655 (7.4)	1,705 (7.6)	1,815 (8.1)	1,705 (7.6)	2,095 (9.3)	1,705 (7.6)	2,565 (11.4)	1,705 (7.6)
	4-5/8 (117)	2,815 (12.5)	1,705 (7.6)	3,085 (13.7)	1,705 (7.6)	3,560 (15.8)	1,705 (7.6)	3,615 (16.1)	1,705 (7.6)
3/4	3-3/8 (86)	1,795 (8.0)	2,870 (12.8)	1,965 (8.7)	3,145 (14.0)	2,270 (10.1)	3,145 (14.0)	2,270 (10.1)	3,145 (14.0)
	4 (102)	2,385 (10.6)	3,145 (14.0)	2,610 (11.6)	3,145 (14.0)	3,015 (13.4)	3,145 (14.0)	3,620 (16.1)	3,145 (14.0)
	5-5/8 (143)	4,420 (19.7)	3,145 (14.0)	4,840 (21.5)	3,145 (14.0)	5,590 (24.9)	3,145 (14.0)	6,265 (27.9)	3,145 (14.0)
7/8	3-7/8 (98)	2,280 (10.1)	2,670 (11.9)	2,500 (11.1)	2,925 (13.0)	2,890 (12.9)	2,925 (13.0)	2,890 (12.9)	2,925 (13.0)
	4-1/2 (114)	2,830 (12.6)	2,925 (13.0)	3,100 (13.8)	2,925 (13.0)	3,780 (16.8)	2,925 (13.0)	4,870 (21.7)	2,925 (13.0)
	6-1/4 (159)	3,775 (16.8)	3,950 (17.6)	4,135 (18.4)	4,325 (19.2)	4,775 (21.2)	4,995 (22.2)	4,775 (21.2)	4,995 (22.2)
1	4-1/2 (114)	3,100 (13.8)	4,830 (21.5)	3,395 (15.1)	5,290 (23.5)	3,920 (17.4)	5,290 (23.5)	3,920 (17.4)	5,290 (23.5)
	5-1/2 (140)	4,135 (18.4)	5,290 (23.5)	4,530 (20.2)	5,290 (23.5)	5,230 (23.3)	5,290 (23.5)	6,405 (28.5)	5,290 (23.5)
	8 (203)	4,910 (21.8)	5,290 (23.5)	5,380 (23.9)	5,290 (23.5)	6,215 (27.6)	5,290 (23.5)	6,215 (27.6)	5,290 (23.5)
1-1/4	5-1/2 (140)	4,630 (20.6)	6,640 (29.5)	5,070 (22.6)	7,275 (32.4)	5,850 (26.0)	7,275 (32.4)	5,850 (26.0)	7,275 (32.4)
	6-1/2 (165)	5,620 (25.0)	7,275 (32.4)	6,160 (27.4)	7,275 (32.4)	7,110 (31.6)	7,275 (32.4)	9,340 (41.5)	7,275 (32.4)

1. Tabulated load values are for anchors installed in uncracked concrete. Concrete compressive strength must be at the minimum at the time of installation.
2. Allowable load capacities are calculated using an applied safety factor of 4.0.
3. Allowable load capacities must be multiplied by reduction factors when anchor spacing or edge distances are less than critical distances.
4. Linear interpolation may be used to determine allowable loads for intermediate embedments and compressive strengths.
5. For lightweight concrete multiply tabulated allowable load values by a reduction factor of 0.60.

MECHANICAL ANCHORS

POWER-STUD® + SD1
Wedge Expansion Anchor

LOAD ADJUSTMENT FACTORS FOR NORMAL-WEIGHT CONCRETE

Spacing Reduction Factors - Tension (F_{NS})

Diameter (in)	1/4		3/8				1/2			5/8		
Nominal Embedment h _{nom} (in)	1-1/8	1-3/4	1-5/8	1-7/8	2-3/8	2-7/8	2-1/4	2-1/2	3-3/4	2-3/4	3-3/8	4-5/8
Minimum Spacing S _{min} (in)	1-1/2	2-1/4	2-1/4	2-1/2	3-1/2	2-1/2	3	4	2	3-3/4	3-1/2	4-1/4
1-1/2	0.85	-	-	-	-	-	-	-	-	-	-	-
1-3/4	0.88	-	-	-	-	-	-	-	-	-	-	-
2	0.92	-	-	-	-	-	-	-	0.66	-	-	-
2-1/4	0.95	0.78	0.86	-	-	-	-	-	0.67	-	-	-
2-1/2	0.98	0.80	0.88	0.86	-	0.69	-	-	0.68	-	-	-
2-3/4	1.00	0.83	0.91	0.88	-	0.71	-	0.81	0.69	-	-	-
3	1.00	0.85	0.93	0.89	-	0.72	0.85	0.82	0.70	-	-	-
3-1/2	1.00	0.90	0.98	0.93	0.84	0.75	0.88	0.85	0.72	-	0.74	-
4	1.00	0.95	1.00	0.96	0.87	0.78	0.92	0.88	0.75	0.87	0.77	-
4-1/4	1.00	0.98	1.00	0.98	0.89	0.80	0.93	0.90	0.76	0.88	0.78	0.72
4-1/2	1.00	1.00	1.00	1.00	0.90	0.82	0.95	0.91	0.77	0.90	0.80	0.73
5	1.00	1.00	1.00	1.00	0.94	0.85	0.98	0.94	0.79	0.92	0.82	0.75
5 1/2	1.00	1.00	1.00	1.00	0.97	0.88	1.00	0.97	0.81	0.95	0.85	0.77
6	1.00	1.00	1.00	1.00	1.00	0.91	1.00	1.00	0.83	0.98	0.88	0.79
6-1/2	1.00	1.00	1.00	1.00	1.00	0.94	1.00	1.00	0.86	1.00	0.90	0.80
7	1.00	1.00	1.00	1.00	1.00	0.97	1.00	1.00	0.88	1.00	0.93	0.82
7-1/2	1.00	1.00	1.00	1.00	1.00	1.00	1.00	1.00	0.90	1.00	0.96	0.84
8	1.00	1.00	1.00	1.00	1.00	1.00	1.00	1.00	0.92	1.00	0.99	0.86
8-1/2	1.00	1.00	1.00	1.00	1.00	1.00	1.00	1.00	0.94	1.00	1.00	0.88
9	1.00	1.00	1.00	1.00	1.00	1.00	1.00	1.00	0.97	1.00	1.00	0.89
9-1/2	1.00	1.00	1.00	1.00	1.00	1.00	1.00	1.00	0.99	1.00	1.00	0.91
10	1.00	1.00	1.00	1.00	1.00	1.00	1.00	1.00	1.00	1.00	1.00	0.93
10-1/2	1.00	1.00	1.00	1.00	1.00	1.00	1.00	1.00	1.00	1.00	1.00	0.95
11	1.00	1.00	1.00	1.00	1.00	1.00	1.00	1.00	1.00	1.00	1.00	0.96
11-1/2	1.00	1.00	1.00	1.00	1.00	1.00	1.00	1.00	1.00	1.00	1.00	0.98
12	1.00	1.00	1.00	1.00	1.00	1.00	1.00	1.00	1.00	1.00	1.00	1.00
12-1/2	1.00	1.00	1.00	1.00	1.00	1.00	1.00	1.00	1.00	1.00	1.00	1.00
13	1.00	1.00	1.00	1.00	1.00	1.00	1.00	1.00	1.00	1.00	1.00	1.00
13-1/2	1.00	1.00	1.00	1.00	1.00	1.00	1.00	1.00	1.00	1.00	1.00	1.00
14	1.00	1.00	1.00	1.00	1.00	1.00	1.00	1.00	1.00	1.00	1.00	1.00
14-1/2	1.00	1.00	1.00	1.00	1.00	1.00	1.00	1.00	1.00	1.00	1.00	1.00
15	1.00	1.00	1.00	1.00	1.00	1.00	1.00	1.00	1.00	1.00	1.00	1.00
15-1/2	1.00	1.00	1.00	1.00	1.00	1.00	1.00	1.00	1.00	1.00	1.00	1.00
16-1/2	1.00	1.00	1.00	1.00	1.00	1.00	1.00	1.00	1.00	1.00	1.00	1.00
16	1.00	1.00	1.00	1.00	1.00	1.00	1.00	1.00	1.00	1.00	1.00	1.00
17	1.00	1.00	1.00	1.00	1.00	1.00	1.00	1.00	1.00	1.00	1.00	1.00
17-1/2	1.00	1.00	1.00	1.00	1.00	1.00	1.00	1.00	1.00	1.00	1.00	1.00
18	1.00	1.00	1.00	1.00	1.00	1.00	1.00	1.00	1.00	1.00	1.00	1.00
18-1/2	1.00	1.00	1.00	1.00	1.00	1.00	1.00	1.00	1.00	1.00	1.00	1.00
19	1.00	1.00	1.00	1.00	1.00	1.00	1.00	1.00	1.00	1.00	1.00	1.00
19-1/2	1.00	1.00	1.00	1.00	1.00	1.00	1.00	1.00	1.00	1.00	1.00	1.00
20	1.00	1.00	1.00	1.00	1.00	1.00	1.00	1.00	1.00	1.00	1.00	1.00
20-5/8	1.00	1.00	1.00	1.00	1.00	1.00	1.00	1.00	1.00	1.00	1.00	1.00

Spacing Distance (inches)

MECHANICAL ANCHORS

POWER-STUD® + SD1

Wedge Expansion Anchor

Spacing Reduction Factors - Tension (F_{NS})

Diameter (in)	3/4			7/8			1			1-1/4		
	3-3/8	4	5-5/8	3-7/8	4-1/2	6-1/4	4-1/2	5-1/2	8	5-1/2	6-1/2	
Nominal Embedment h _{nom} (in)												
Minimum Spacing S _{min} (in)	4-1/2	4-3/4	4	5-1/4	6-1/2	5-1/4	6	8	6	7-1/2	8	
Spacing Distance (inches)	1-1/2	-	-	-	-	-	-	-	-	-	-	
	1-3/4	-	-	-	-	-	-	-	-	-	-	
	2	-	-	-	-	-	-	-	-	-	-	
	2-1/4	-	-	-	-	-	-	-	-	-	-	
	2-1/2	-	-	-	-	-	-	-	-	-	-	
	2-3/4	-	-	-	-	-	-	-	-	-	-	
	3	-	-	-	-	-	-	-	-	-	-	
	3-1/2	-	-	-	-	-	-	-	-	-	-	-
	4	-	-	0.73	-	-	-	-	-	-	-	-
	4-1/4	-	-	0.73	-	-	-	-	-	-	-	-
	4-1/2	0.86	-	0.74	-	-	-	-	-	-	-	-
	5	0.88	0.83	0.75	-	-	-	-	-	-	-	-
	5 1/2	0.91	0.85	0.77	0.87	-	0.77	-	-	-	-	-
	6	0.93	0.87	0.78	0.89	-	0.78	0.86	-	0.75	-	-
	6-1/2	0.95	0.89	0.79	0.91	0.85	0.79	0.87	-	0.76	-	-
	7	0.98	0.91	0.81	0.93	0.87	0.80	0.89	-	0.77	-	-
	7-1/2	1.00	0.93	0.82	0.95	0.89	0.82	0.91	-	0.78	0.85	-
	8	1.00	0.95	0.83	0.97	0.91	0.83	0.93	0.84	0.78	0.86	0.82
	8-1/2	1.00	0.97	0.85	0.99	0.93	0.84	0.94	0.85	0.79	0.88	0.83
	9	1.00	0.99	0.86	1.00	0.94	0.85	0.96	0.87	0.80	0.89	0.84
9-1/2	1.00	1.00	0.87	1.00	0.96	0.86	0.98	0.89	0.81	0.90	0.85	
10	1.00	1.00	0.89	1.00	0.98	0.87	1.00	0.90	0.82	0.92	0.86	
10-1/2	1.00	1.00	0.90	1.00	1.00	0.88	1.00	0.92	0.83	0.93	0.87	
11	1.00	1.00	0.91	1.00	1.00	0.89	1.00	0.93	0.84	0.94	0.88	
11-1/2	1.00	1.00	0.93	1.00	1.00	0.90	1.00	0.95	0.84	0.96	0.90	
12	1.00	1.00	0.94	1.00	1.00	0.92	1.00	0.96	0.85	0.97	0.91	
12-1/2	1.00	1.00	0.95	1.00	1.00	0.93	1.00	0.98	0.86	0.98	0.92	
13	1.00	1.00	0.97	1.00	1.00	0.94	1.00	1.00	0.87	1.00	0.93	
13-1/2	1.00	1.00	0.98	1.00	1.00	0.95	1.00	1.00	0.88	1.00	0.94	
14	1.00	1.00	0.99	1.00	1.00	0.96	1.00	1.00	0.89	1.00	0.95	
14-1/2	1.00	1.00	1.00	1.00	1.00	0.97	1.00	1.00	0.90	1.00	0.96	
15	1.00	1.00	1.00	1.00	1.00	0.98	1.00	1.00	0.90	1.00	0.97	
15-1/2	1.00	1.00	1.00	1.00	1.00	0.99	1.00	1.00	0.91	1.00	0.99	
16-1/2	1.00	1.00	1.00	1.00	1.00	1.00	1.00	1.00	0.93	1.00	1.00	
16	1.00	1.00	1.00	1.00	1.00	1.00	1.00	1.00	0.92	1.00	1.00	
17	1.00	1.00	1.00	1.00	1.00	1.00	1.00	1.00	0.94	1.00	1.00	
17-1/2	1.00	1.00	1.00	1.00	1.00	1.00	1.00	1.00	0.95	1.00	1.00	
18	1.00	1.00	1.00	1.00	1.00	1.00	1.00	1.00	0.96	1.00	1.00	
18-1/2	1.00	1.00	1.00	1.00	1.00	1.00	1.00	1.00	0.96	1.00	1.00	
19	1.00	1.00	1.00	1.00	1.00	1.00	1.00	1.00	0.97	1.00	1.00	
19-1/2	1.00	1.00	1.00	1.00	1.00	1.00	1.00	1.00	0.98	1.00	1.00	
20	1.00	1.00	1.00	1.00	1.00	1.00	1.00	1.00	0.99	1.00	1.00	
20-5/8	1.00	1.00	1.00	1.00	1.00	1.00	1.00	1.00	1.00	1.00	1.00	

MECHANICAL ANCHORS

POWER-STUD® + SD1
Wedge Expansion Anchor

Spacing Reduction Factors - Shear (F_{VS})

Diameter (in)	1/4		3/8				1/2			5/8		
Nominal Embedment h_{nom} (in)	1-1/8	1-3/4	1-5/8	1-7/8	2-3/8	2-7/8	2-1/4	2-1/2	3-3/4	2-3/4	3-3/8	4-5/8
Minimum Spacing s_{min} (in)	1-1/2	2-1/4	2-1/4	2-1/2	3-1/2	2-1/2	3	4	2	3-3/4	3-1/2	4-1/4
1-1/2	0.91	-	-	-	-	-	-	-	-	-	-	-
1-3/4	0.93	-	-	-	-	-	-	-	-	-	-	-
2	0.95	-	-	-	-	-	-	-	0.77	-	-	-
2-1/4	0.97	0.85	0.92	-	-	-	-	-	0.78	-	-	-
2-1/2	0.99	0.87	0.93	0.93	-	0.78	-	-	0.79	-	-	-
2-3/4	1.00	0.88	0.95	0.94	-	0.79	-	0.89	0.79	-	-	-
3	1.00	0.90	0.96	0.94	-	0.80	0.91	0.90	0.80	-	-	-
3-1/2	1.00	0.93	0.99	0.96	0.90	0.82	0.93	0.92	0.81	-	0.82	-
4	1.00	0.97	1.00	0.98	0.92	0.84	0.95	0.93	0.83	0.93	0.84	-
4-1/4	1.00	0.98	1.00	0.99	0.93	0.86	0.96	0.94	0.84	0.93	0.85	0.82
4-1/2	1.00	1.00	1.00	1.00	0.94	0.87	0.97	0.95	0.84	0.94	0.86	0.82
5	1.00	1.00	1.00	1.00	0.96	0.89	0.99	0.97	0.86	0.96	0.88	0.83
5 1/2	1.00	1.00	1.00	1.00	0.98	0.91	1.00	0.98	0.87	0.97	0.90	0.85
6	1.00	1.00	1.00	1.00	1.00	0.93	1.00	1.00	0.89	0.99	0.91	0.86
6-1/2	1.00	1.00	1.00	1.00	1.00	0.96	1.00	1.00	0.90	1.00	0.93	0.87
7	1.00	1.00	1.00	1.00	1.00	0.98	1.00	1.00	0.92	1.00	0.95	0.88
7-1/2	1.00	1.00	1.00	1.00	1.00	1.00	1.00	1.00	0.93	1.00	0.97	0.89
8	1.00	1.00	1.00	1.00	1.00	1.00	1.00	1.00	0.95	1.00	0.99	0.90
8-1/2	1.00	1.00	1.00	1.00	1.00	1.00	1.00	1.00	0.96	1.00	1.00	0.92
9	1.00	1.00	1.00	1.00	1.00	1.00	1.00	1.00	0.98	1.00	1.00	0.93
9-1/2	1.00	1.00	1.00	1.00	1.00	1.00	1.00	1.00	0.99	1.00	1.00	0.94
10	1.00	1.00	1.00	1.00	1.00	1.00	1.00	1.00	1.00	1.00	1.00	0.95
10-1/2	1.00	1.00	1.00	1.00	1.00	1.00	1.00	1.00	1.00	1.00	1.00	0.96
11	1.00	1.00	1.00	1.00	1.00	1.00	1.00	1.00	1.00	1.00	1.00	0.98
11-1/2	1.00	1.00	1.00	1.00	1.00	1.00	1.00	1.00	1.00	1.00	1.00	0.99
12	1.00	1.00	1.00	1.00	1.00	1.00	1.00	1.00	1.00	1.00	1.00	1.00
12-1/2	1.00	1.00	1.00	1.00	1.00	1.00	1.00	1.00	1.00	1.00	1.00	1.00
13	1.00	1.00	1.00	1.00	1.00	1.00	1.00	1.00	1.00	1.00	1.00	1.00
13-1/2	1.00	1.00	1.00	1.00	1.00	1.00	1.00	1.00	1.00	1.00	1.00	1.00
14	1.00	1.00	1.00	1.00	1.00	1.00	1.00	1.00	1.00	1.00	1.00	1.00
14-1/2	1.00	1.00	1.00	1.00	1.00	1.00	1.00	1.00	1.00	1.00	1.00	1.00
15	1.00	1.00	1.00	1.00	1.00	1.00	1.00	1.00	1.00	1.00	1.00	1.00
15-1/2	1.00	1.00	1.00	1.00	1.00	1.00	1.00	1.00	1.00	1.00	1.00	1.00
16-1/2	1.00	1.00	1.00	1.00	1.00	1.00	1.00	1.00	1.00	1.00	1.00	1.00
16	1.00	1.00	1.00	1.00	1.00	1.00	1.00	1.00	1.00	1.00	1.00	1.00
17	1.00	1.00	1.00	1.00	1.00	1.00	1.00	1.00	1.00	1.00	1.00	1.00
17-1/2	1.00	1.00	1.00	1.00	1.00	1.00	1.00	1.00	1.00	1.00	1.00	1.00
18	1.00	1.00	1.00	1.00	1.00	1.00	1.00	1.00	1.00	1.00	1.00	1.00
18-1/2	1.00	1.00	1.00	1.00	1.00	1.00	1.00	1.00	1.00	1.00	1.00	1.00
19	1.00	1.00	1.00	1.00	1.00	1.00	1.00	1.00	1.00	1.00	1.00	1.00
19-1/2	1.00	1.00	1.00	1.00	1.00	1.00	1.00	1.00	1.00	1.00	1.00	1.00
20	1.00	1.00	1.00	1.00	1.00	1.00	1.00	1.00	1.00	1.00	1.00	1.00
20-5/8	1.00	1.00	1.00	1.00	1.00	1.00	1.00	1.00	1.00	1.00	1.00	1.00

Spacing Distance (inches)

Spacing Reduction Factors - Shear (F_{vs})

Diameter (in)		3/4			7/8			1			1-1/4	
Nominal Embedment h_{nom} (in)	3-3/8	4	5-5/8	3-7/8	4-1/2	6-1/4	4-1/2	5-1/2	8	5-1/2	6-1/2	
Minimum Spacing s_{min} (in)	4-1/2	4-3/4	4	5-1/4	6-1/2	5-1/4	6	8	6	7-1/2	8	
Spacing Distance (inches)	1-1/2	-	-	-	-	-	-	-	-	-	-	
	1-3/4	-	-	-	-	-	-	-	-	-	-	
	2	-	-	-	-	-	-	-	-	-	-	
	2-1/4	-	-	-	-	-	-	-	-	-	-	
	2-1/2	-	-	-	-	-	-	-	-	-	-	
	2-3/4	-	-	-	-	-	-	-	-	-	-	
	3	-	-	-	-	-	-	-	-	-	-	
	3-1/2	-	-	-	-	-	-	-	-	-	-	-
	4	-	-	0.84	-	-	-	-	-	-	-	-
	4-1/4	-	-	0.84	-	-	-	-	-	-	-	-
	4-1/2	0.92	-	0.84	-	-	-	-	-	-	-	-
	5	0.93	0.90	0.85	-	-	-	-	-	-	-	-
	5 1/2	0.95	0.91	0.86	0.93	-	0.87	-	-	-	-	-
	6	0.96	0.92	0.87	0.94	-	0.88	0.92	-	0.86	-	-
	6-1/2	0.97	0.93	0.88	0.95	0.91	0.88	0.93	-	0.86	-	-
	7	0.99	0.94	0.88	0.96	0.92	0.89	0.94	-	0.87	-	-
	7-1/2	1.00	0.96	0.89	0.97	0.93	0.90	0.95	-	0.87	0.91	-
	8	1.00	0.97	0.90	0.99	0.94	0.90	0.96	0.90	0.88	0.92	0.89
	8-1/2	1.00	0.98	0.91	1.00	0.96	0.91	0.97	0.91	0.88	0.93	0.90
	9	1.00	0.99	0.92	1.00	0.97	0.91	0.98	0.92	0.89	0.94	0.91
9-1/2	1.00	1.00	0.92	1.00	0.98	0.92	0.99	0.93	0.89	0.94	0.91	
10	1.00	1.00	0.93	1.00	0.99	0.93	1.00	0.94	0.90	0.95	0.92	
10-1/2	1.00	1.00	0.94	1.00	1.00	0.93	1.00	0.95	0.90	0.96	0.93	
11	1.00	1.00	0.95	1.00	1.00	0.94	1.00	0.96	0.91	0.97	0.93	
11-1/2	1.00	1.00	0.96	1.00	1.00	0.95	1.00	0.97	0.91	0.98	0.94	
12	1.00	1.00	0.96	1.00	1.00	0.95	1.00	0.98	0.92	0.98	0.95	
12-1/2	1.00	1.00	0.97	1.00	1.00	0.96	1.00	0.99	0.92	0.99	0.95	
13	1.00	1.00	0.98	1.00	1.00	0.97	1.00	1.00	0.93	1.00	0.96	
13-1/2	1.00	1.00	0.99	1.00	1.00	0.97	1.00	1.00	0.93	1.00	0.97	
14	1.00	1.00	1.00	1.00	1.00	0.98	1.00	1.00	0.94	1.00	0.97	
14-1/2	1.00	1.00	1.00	1.00	1.00	0.98	1.00	1.00	0.94	1.00	0.98	
15	1.00	1.00	1.00	1.00	1.00	0.99	1.00	1.00	0.95	1.00	0.99	
15-1/2	1.00	1.00	1.00	1.00	1.00	1.00	1.00	1.00	0.95	1.00	0.99	
16-1/2	1.00	1.00	1.00	1.00	1.00	1.00	1.00	1.00	0.96	1.00	1.00	
16	1.00	1.00	1.00	1.00	1.00	1.00	1.00	1.00	0.96	1.00	1.00	
17	1.00	1.00	1.00	1.00	1.00	1.00	1.00	1.00	0.96	1.00	1.00	
17-1/2	1.00	1.00	1.00	1.00	1.00	1.00	1.00	1.00	0.97	1.00	1.00	
18	1.00	1.00	1.00	1.00	1.00	1.00	1.00	1.00	0.97	1.00	1.00	
18-1/2	1.00	1.00	1.00	1.00	1.00	1.00	1.00	1.00	0.98	1.00	1.00	
19	1.00	1.00	1.00	1.00	1.00	1.00	1.00	1.00	0.98	1.00	1.00	
19-1/2	1.00	1.00	1.00	1.00	1.00	1.00	1.00	1.00	0.99	1.00	1.00	
20	1.00	1.00	1.00	1.00	1.00	1.00	1.00	1.00	0.99	1.00	1.00	
20-5/8	1.00	1.00	1.00	1.00	1.00	1.00	1.00	1.00	1.00	1.00	1.00	

MECHANICAL ANCHORS

POWER-STUD® + SD1
Wedge Expansion Anchor

Edge Distance Reduction Factors - Tension (F_{NC})

Diameter (in)	1/4		3/8				1/2			5/8		
	Nominal Embedment h _{nom} (in)	1-1/8	1-3/4	1-5/8	1-7/8	2-3/8	2-7/8	2-1/4	2-1/2	3-3/4	2-3/4	3-3/8
Min. Edge Distance c _{min} (in)	1-3/4	1-3/4	3	2-3/4	2-1/4	2-1/2	4	2-3/4	2-3/4	5	4	4-1/4
1-3/4	0.50	0.50	-	-	-	-	-	-	-	-	-	-
2	0.57	0.57	-	-	-	-	-	-	-	-	-	-
2-1/4	0.64	0.64	-	-	0.35	-	-	-	-	-	-	-
2-1/2	0.71	0.71	-	-	0.38	0.58	-	-	-	-	-	-
2-3/4	0.79	0.79	-	0.92	0.42	0.64	-	0.34	0.34	-	-	-
3	0.86	0.86	0.60	1.00	0.46	0.70	-	0.38	0.38	-	-	-
3-1/4	0.93	0.93	0.65	1.00	0.50	0.75	-	0.41	0.41	-	-	-
3-1/2	1.00	1.00	0.70	1.00	0.54	0.81	-	0.44	0.44	-	-	-
4	1.00	1.00	0.80	1.00	0.62	0.93	0.57	0.50	0.50	-	0.53	-
4-1/4	1.00	1.00	0.85	1.00	0.65	0.99	0.61	0.53	0.53	-	0.57	0.43
4-1/2	1.00	1.00	0.90	1.00	0.69	1.00	0.64	0.56	0.56	-	0.60	0.45
5	1.00	1.00	1.00	1.00	0.77	1.00	0.71	0.63	0.63	0.59	0.67	0.50
5-1/2	1.00	1.00	1.00	1.00	0.85	1.00	0.79	0.69	0.69	0.65	0.73	0.55
6	1.00	1.00	1.00	1.00	0.92	1.00	0.86	0.75	0.75	0.71	0.80	0.60
6-1/2	1.00	1.00	1.00	1.00	1.00	1.00	0.93	0.81	0.81	0.76	0.87	0.65
7	1.00	1.00	1.00	1.00	1.00	1.00	1.00	0.88	0.88	0.82	0.93	0.70
7-1/2	1.00	1.00	1.00	1.00	1.00	1.00	1.00	0.94	0.94	0.88	1.00	0.75
8	1.00	1.00	1.00	1.00	1.00	1.00	1.00	1.00	1.00	0.94	1.00	0.80
8-1/2	1.00	1.00	1.00	1.00	1.00	1.00	1.00	1.00	1.00	1.00	1.00	0.85
9	1.00	1.00	1.00	1.00	1.00	1.00	1.00	1.00	1.00	1.00	1.00	0.90
9-1/2	1.00	1.00	1.00	1.00	1.00	1.00	1.00	1.00	1.00	1.00	1.00	0.95
10	1.00	1.00	1.00	1.00	1.00	1.00	1.00	1.00	1.00	1.00	1.00	1.00
10-1/2	1.00	1.00	1.00	1.00	1.00	1.00	1.00	1.00	1.00	1.00	1.00	1.00
11	1.00	1.00	1.00	1.00	1.00	1.00	1.00	1.00	1.00	1.00	1.00	1.00
11-1/2	1.00	1.00	1.00	1.00	1.00	1.00	1.00	1.00	1.00	1.00	1.00	1.00
12	1.00	1.00	1.00	1.00	1.00	1.00	1.00	1.00	1.00	1.00	1.00	1.00
12-1/2	1.00	1.00	1.00	1.00	1.00	1.00	1.00	1.00	1.00	1.00	1.00	1.00
13	1.00	1.00	1.00	1.00	1.00	1.00	1.00	1.00	1.00	1.00	1.00	1.00
13-1/2	1.00	1.00	1.00	1.00	1.00	1.00	1.00	1.00	1.00	1.00	1.00	1.00
14	1.00	1.00	1.00	1.00	1.00	1.00	1.00	1.00	1.00	1.00	1.00	1.00
14-1/2	1.00	1.00	1.00	1.00	1.00	1.00	1.00	1.00	1.00	1.00	1.00	1.00
15	1.00	1.00	1.00	1.00	1.00	1.00	1.00	1.00	1.00	1.00	1.00	1.00
15-1/2	1.00	1.00	1.00	1.00	1.00	1.00	1.00	1.00	1.00	1.00	1.00	1.00
16	1.00	1.00	1.00	1.00	1.00	1.00	1.00	1.00	1.00	1.00	1.00	1.00
16-1/2	1.00	1.00	1.00	1.00	1.00	1.00	1.00	1.00	1.00	1.00	1.00	1.00
17	1.00	1.00	1.00	1.00	1.00	1.00	1.00	1.00	1.00	1.00	1.00	1.00
17-1/2	1.00	1.00	1.00	1.00	1.00	1.00	1.00	1.00	1.00	1.00	1.00	1.00
18	1.00	1.00	1.00	1.00	1.00	1.00	1.00	1.00	1.00	1.00	1.00	1.00
18-1/2	1.00	1.00	1.00	1.00	1.00	1.00	1.00	1.00	1.00	1.00	1.00	1.00
19	1.00	1.00	1.00	1.00	1.00	1.00	1.00	1.00	1.00	1.00	1.00	1.00
19-1/2	1.00	1.00	1.00	1.00	1.00	1.00	1.00	1.00	1.00	1.00	1.00	1.00
20	1.00	1.00	1.00	1.00	1.00	1.00	1.00	1.00	1.00	1.00	1.00	1.00
21	1.00	1.00	1.00	1.00	1.00	1.00	1.00	1.00	1.00	1.00	1.00	1.00
22	1.00	1.00	1.00	1.00	1.00	1.00	1.00	1.00	1.00	1.00	1.00	1.00
23	1.00	1.00	1.00	1.00	1.00	1.00	1.00	1.00	1.00	1.00	1.00	1.00
24	1.00	1.00	1.00	1.00	1.00	1.00	1.00	1.00	1.00	1.00	1.00	1.00
25	1.00	1.00	1.00	1.00	1.00	1.00	1.00	1.00	1.00	1.00	1.00	1.00
26	1.00	1.00	1.00	1.00	1.00	1.00	1.00	1.00	1.00	1.00	1.00	1.00
27	1.00	1.00	1.00	1.00	1.00	1.00	1.00	1.00	1.00	1.00	1.00	1.00
27-1/2	1.00	1.00	1.00	1.00	1.00	1.00	1.00	1.00	1.00	1.00	1.00	1.00

Edge Distance (inches)

Edge Distance Reduction Factors - Tension (F_{NC})

Diameter (in)	3/4			7/8			1			1-1/4		
	3-3/8	4	5-5/8	3-7/8	4-1/2	6-1/4	4-1/2	5-1/2	8	5-1/2	6-1/2	
Nominal Embedment h _{nom} (in)												
Min. Edge Distance c _{min} (in)	6	5	3-3/4	7	7	7	8	8	8	10	8	
Edge Distance (inches)	1-3/4	-	-	-	-	-	-	-	-	-	-	
	2	-	-	-	-	-	-	-	-	-	-	
	2-1/4	-	-	-	-	-	-	-	-	-	-	
	2-1/2	-	-	-	-	-	-	-	-	-	-	
	2-3/4	-	-	-	-	-	-	-	-	-	-	
	3	-	-	-	-	-	-	-	-	-	-	
	3-1/4	-	-	-	-	-	-	-	-	-	-	
	3-1/2	-	-	-	-	-	-	-	-	-	-	
	4	-	-	0.33	-	-	-	-	-	-	-	-
	4-1/4	-	-	0.35	-	-	-	-	-	-	-	-
	4-1/2	-	-	0.38	-	-	-	-	-	-	-	-
	5	-	0.45	0.42	-	-	-	-	-	-	-	-
	5-1/2	-	0.50	0.46	-	-	-	-	-	-	-	-
	6	0.60	0.55	0.50	-	-	-	-	-	-	-	-
	6-1/2	0.65	0.59	0.54	-	-	-	-	-	-	-	-
	7	0.70	0.64	0.58	0.61	0.61	0.33	-	-	-	-	-
	7-1/2	0.75	0.68	0.63	0.65	0.65	0.36	-	-	-	-	-
	8	0.80	0.73	0.67	0.70	0.70	0.38	0.59	0.67	0.29	-	0.40
	8-1/2	0.85	0.77	0.71	0.74	0.74	0.40	0.63	0.71	0.31	-	0.43
	9	0.90	0.82	0.75	0.78	0.78	0.43	0.67	0.75	0.33	-	0.45
	9-1/2	0.95	0.86	0.79	0.83	0.83	0.45	0.70	0.79	0.35	-	0.48
	10	1.00	0.91	0.83	0.87	0.87	0.48	0.74	0.83	0.36	0.57	0.50
	10-1/2	1.00	0.95	0.88	0.91	0.91	0.50	0.78	0.88	0.38	0.60	0.53
	11	1.00	1.00	0.92	0.96	0.96	0.52	0.81	0.92	0.40	0.63	0.55
	11-1/2	1.00	1.00	0.96	1.00	1.00	0.55	0.85	0.96	0.42	0.66	0.58
	12	1.00	1.00	1.00	1.00	1.00	0.57	0.89	1.00	0.44	0.69	0.60
	12-1/2	1.00	1.00	1.00	1.00	1.00	0.60	0.93	1.00	0.45	0.71	0.63
	13	1.00	1.00	1.00	1.00	1.00	0.62	0.96	1.00	0.47	0.74	0.65
	13-1/2	1.00	1.00	1.00	1.00	1.00	0.64	1.00	1.00	0.49	0.77	0.68
	14	1.00	1.00	1.00	1.00	1.00	0.67	1.00	1.00	0.51	0.80	0.70
14-1/2	1.00	1.00	1.00	1.00	1.00	0.69	1.00	1.00	0.53	0.83	0.73	
15	1.00	1.00	1.00	1.00	1.00	0.71	1.00	1.00	0.55	0.86	0.75	
15-1/2	1.00	1.00	1.00	1.00	1.00	0.74	1.00	1.00	0.56	0.89	0.78	
16	1.00	1.00	1.00	1.00	1.00	0.76	1.00	1.00	0.58	0.91	0.80	
16-1/2	1.00	1.00	1.00	1.00	1.00	0.79	1.00	1.00	0.60	0.94	0.83	
17	1.00	1.00	1.00	1.00	1.00	0.81	1.00	1.00	0.62	0.97	0.85	
17-1/2	1.00	1.00	1.00	1.00	1.00	0.83	1.00	1.00	0.64	1.00	0.88	
18	1.00	1.00	1.00	1.00	1.00	0.86	1.00	1.00	0.65	1.00	0.90	
18-1/2	1.00	1.00	1.00	1.00	1.00	0.88	1.00	1.00	0.67	1.00	0.93	
19	1.00	1.00	1.00	1.00	1.00	0.90	1.00	1.00	0.69	1.00	0.95	
19-1/2	1.00	1.00	1.00	1.00	1.00	0.93	1.00	1.00	0.71	1.00	0.98	
20	1.00	1.00	1.00	1.00	1.00	0.95	1.00	1.00	0.73	1.00	1.00	
21	1.00	1.00	1.00	1.00	1.00	1.00	1.00	1.00	0.76	1.00	1.00	
22	1.00	1.00	1.00	1.00	1.00	1.00	1.00	1.00	0.80	1.00	1.00	
23	1.00	1.00	1.00	1.00	1.00	1.00	1.00	1.00	0.84	1.00	1.00	
24	1.00	1.00	1.00	1.00	1.00	1.00	1.00	1.00	0.87	1.00	1.00	
25	1.00	1.00	1.00	1.00	1.00	1.00	1.00	1.00	0.91	1.00	1.00	
26	1.00	1.00	1.00	1.00	1.00	1.00	1.00	1.00	0.95	1.00	1.00	
27	1.00	1.00	1.00	1.00	1.00	1.00	1.00	1.00	0.98	1.00	1.00	
27-1/2	1.00	1.00	1.00	1.00	1.00	1.00	1.00	1.00	1.00	1.00	1.00	

MECHANICAL ANCHORS

POWER-STUD® + SD1
Wedge Expansion Anchor

Edge Distance Reduction Factors - Shear (F_{vc})

Diameter (in)	1/4		3/8				1/2			5/8			
	Nominal Embedment h_{nom} (in)	1-1/8	1-3/4	1-5/8	1-7/8	2-3/8	2-7/8	2-1/4	2-1/2	3-3/4	2-3/4	3-3/8	4-5/8
	Min. Edge Distance C_{min} (in)	1-3/4	1-3/4	3	2-3/4	2-1/4	2-1/2	4	2-3/4	2-3/4	5	4	4-1/4
Edge Distance (inches)	1-3/4	0.67	0.39	-	-	-	-	-	-	-	-	-	-
	2	0.76	0.44	-	-	-	-	-	-	-	-	-	-
	2-1/4	0.86	0.50	-	-	0.38	-	-	-	-	-	-	-
	2-1/2	0.95	0.56	-	-	0.42	0.33	-	-	-	-	-	-
	2-3/4	1.00	0.61	-	0.61	0.46	0.37	-	0.46	0.28	-	-	-
	3	1.00	0.67	0.80	0.67	0.50	0.40	-	0.50	0.31	-	-	-
	3-1/4	1.00	0.72	0.87	0.72	0.54	0.43	-	0.54	0.33	-	-	-
	3-1/2	1.00	0.78	0.93	0.78	0.58	0.47	-	0.58	0.36	-	-	-
	4	1.00	0.89	1.00	0.89	0.67	0.53	0.76	0.67	0.41	-	0.48	-
	4-1/4	1.00	0.94	1.00	0.94	0.71	0.57	0.81	0.71	0.44	-	0.52	0.35
	4-1/2	1.00	1.00	1.00	1.00	0.75	0.60	0.86	0.75	0.46	-	0.55	0.38
	5	1.00	1.00	1.00	1.00	0.83	0.67	0.95	0.83	0.51	0.78	0.61	0.42
	5-1/2	1.00	1.00	1.00	1.00	0.92	0.73	1.00	0.92	0.56	0.86	0.67	0.46
	6	1.00	1.00	1.00	1.00	1.00	0.80	1.00	1.00	0.62	0.94	0.73	0.50
	6-1/2	1.00	1.00	1.00	1.00	1.00	0.87	1.00	1.00	0.67	1.00	0.79	0.54
	7	1.00	1.00	1.00	1.00	1.00	0.93	1.00	1.00	0.72	1.00	0.85	0.58
	7-1/2	1.00	1.00	1.00	1.00	1.00	1.00	1.00	1.00	0.77	1.00	0.91	0.63
	8	1.00	1.00	1.00	1.00	1.00	1.00	1.00	1.00	0.82	1.00	0.97	0.67
	8-1/2	1.00	1.00	1.00	1.00	1.00	1.00	1.00	1.00	0.87	1.00	1.00	0.71
	9	1.00	1.00	1.00	1.00	1.00	1.00	1.00	1.00	0.92	1.00	1.00	0.75
	9-1/2	1.00	1.00	1.00	1.00	1.00	1.00	1.00	1.00	0.97	1.00	1.00	0.79
10	1.00	1.00	1.00	1.00	1.00	1.00	1.00	1.00	1.00	1.00	1.00	0.83	
10-1/2	1.00	1.00	1.00	1.00	1.00	1.00	1.00	1.00	1.00	1.00	1.00	0.88	
11	1.00	1.00	1.00	1.00	1.00	1.00	1.00	1.00	1.00	1.00	1.00	0.92	
11-1/2	1.00	1.00	1.00	1.00	1.00	1.00	1.00	1.00	1.00	1.00	1.00	0.96	
12	1.00	1.00	1.00	1.00	1.00	1.00	1.00	1.00	1.00	1.00	1.00	1.00	
12-1/2	1.00	1.00	1.00	1.00	1.00	1.00	1.00	1.00	1.00	1.00	1.00	1.00	
13	1.00	1.00	1.00	1.00	1.00	1.00	1.00	1.00	1.00	1.00	1.00	1.00	
13-1/2	1.00	1.00	1.00	1.00	1.00	1.00	1.00	1.00	1.00	1.00	1.00	1.00	
14	1.00	1.00	1.00	1.00	1.00	1.00	1.00	1.00	1.00	1.00	1.00	1.00	
14-1/2	1.00	1.00	1.00	1.00	1.00	1.00	1.00	1.00	1.00	1.00	1.00	1.00	
15	1.00	1.00	1.00	1.00	1.00	1.00	1.00	1.00	1.00	1.00	1.00	1.00	
15-1/2	1.00	1.00	1.00	1.00	1.00	1.00	1.00	1.00	1.00	1.00	1.00	1.00	
16	1.00	1.00	1.00	1.00	1.00	1.00	1.00	1.00	1.00	1.00	1.00	1.00	
16-1/2	1.00	1.00	1.00	1.00	1.00	1.00	1.00	1.00	1.00	1.00	1.00	1.00	
17	1.00	1.00	1.00	1.00	1.00	1.00	1.00	1.00	1.00	1.00	1.00	1.00	
17-1/2	1.00	1.00	1.00	1.00	1.00	1.00	1.00	1.00	1.00	1.00	1.00	1.00	
18	1.00	1.00	1.00	1.00	1.00	1.00	1.00	1.00	1.00	1.00	1.00	1.00	
18-1/2	1.00	1.00	1.00	1.00	1.00	1.00	1.00	1.00	1.00	1.00	1.00	1.00	
19	1.00	1.00	1.00	1.00	1.00	1.00	1.00	1.00	1.00	1.00	1.00	1.00	
19-1/2	1.00	1.00	1.00	1.00	1.00	1.00	1.00	1.00	1.00	1.00	1.00	1.00	
20	1.00	1.00	1.00	1.00	1.00	1.00	1.00	1.00	1.00	1.00	1.00	1.00	
21	1.00	1.00	1.00	1.00	1.00	1.00	1.00	1.00	1.00	1.00	1.00	1.00	

Edge Distance Reduction Factors - Shear (F_v)

Diameter (in)	3/4			7/8			1			1-1/4		
	Nominal Embedment h _{nom} (in)	3-3/8	4	5-5/8	3-7/8	4-1/2	6-1/4	4-1/2	5-1/2	8	5-1/2	6-1/2
Min. Edge Distance C _{min} (in)	6	5	3-3/4	7	7	7	8	8	8	8	10	8
Edge Distance (inches)	1-3/4	-	-	-	-	-	-	-	-	-	-	-
	2	-	-	-	-	-	-	-	-	-	-	-
	2-1/4	-	-	-	-	-	-	-	-	-	-	-
	2-1/2	-	-	-	-	-	-	-	-	-	-	-
	2-3/4	-	-	-	-	-	-	-	-	-	-	-
	3	-	-	-	-	-	-	-	-	-	-	-
	3-1/4	-	-	-	-	-	-	-	-	-	-	-
	3-1/2	-	-	-	-	-	-	-	-	-	-	-
	4	-	-	0.28	-	-	-	-	-	-	-	-
	4-1/4	-	-	0.30	-	-	-	-	-	-	-	-
	4-1/2	-	-	0.32	-	-	-	-	-	-	-	-
	5	-	0.53	0.35	-	-	-	-	-	-	-	-
	5-1/2	-	0.59	0.39	-	-	-	-	-	-	-	-
	6	0.80	0.64	0.42	-	-	-	-	-	-	-	-
	6-1/2	0.87	0.69	0.46	-	-	-	-	-	-	-	-
	7	0.93	0.75	0.49	0.81	0.67	0.44	-	-	-	-	-
	7-1/2	1.00	0.80	0.53	0.87	0.71	0.48	-	-	-	-	-
	8	1.00	0.85	0.56	0.93	0.76	0.51	0.79	0.61	0.39	-	0.50
	8-1/2	1.00	0.91	0.60	0.99	0.81	0.54	0.84	0.65	0.41	-	0.53
	9	1.00	0.96	0.63	1.00	0.86	0.57	0.89	0.69	0.44	-	0.56
	9-1/2	1.00	1.00	0.67	1.00	0.90	0.60	0.94	0.72	0.46	-	0.59
10	1.00	1.00	0.70	1.00	0.95	0.63	0.99	0.76	0.48	0.76	0.62	
10-1/2	1.00	1.00	0.74	1.00	1.00	0.67	1.00	0.80	0.51	0.80	0.65	
11	1.00	1.00	0.77	1.00	1.00	0.70	1.00	0.84	0.53	0.84	0.68	
11-1/2	1.00	1.00	0.81	1.00	1.00	0.73	1.00	0.88	0.56	0.88	0.71	
12	1.00	1.00	0.84	1.00	1.00	0.76	1.00	0.91	0.58	0.91	0.74	
12-1/2	1.00	1.00	0.88	1.00	1.00	0.79	1.00	0.95	0.61	0.95	0.78	
13	1.00	1.00	0.91	1.00	1.00	0.83	1.00	0.99	0.63	0.99	0.81	
13-1/2	1.00	1.00	0.95	1.00	1.00	0.86	1.00	1.00	0.65	1.00	0.84	
14	1.00	1.00	0.98	1.00	1.00	0.89	1.00	1.00	0.68	1.00	0.87	
14-1/2	1.00	1.00	1.00	1.00	1.00	0.92	1.00	1.00	0.70	1.00	0.90	
15	1.00	1.00	1.00	1.00	1.00	0.95	1.00	1.00	0.73	1.00	0.93	
15-1/2	1.00	1.00	1.00	1.00	1.00	0.98	1.00	1.00	0.75	1.00	0.96	
16	1.00	1.00	1.00	1.00	1.00	1.00	1.00	1.00	0.78	1.00	0.99	
16-1/2	1.00	1.00	1.00	1.00	1.00	1.00	1.00	1.00	0.80	1.00	1.00	
17	1.00	1.00	1.00	1.00	1.00	1.00	1.00	1.00	0.82	1.00	1.00	
17-1/2	1.00	1.00	1.00	1.00	1.00	1.00	1.00	1.00	0.85	1.00	1.00	
18	1.00	1.00	1.00	1.00	1.00	1.00	1.00	1.00	0.87	1.00	1.00	
18-1/2	1.00	1.00	1.00	1.00	1.00	1.00	1.00	1.00	0.90	1.00	1.00	
19	1.00	1.00	1.00	1.00	1.00	1.00	1.00	1.00	0.92	1.00	1.00	
19-1/2	1.00	1.00	1.00	1.00	1.00	1.00	1.00	1.00	0.95	1.00	1.00	
20	1.00	1.00	1.00	1.00	1.00	1.00	1.00	1.00	0.97	1.00	1.00	
21	1.00	1.00	1.00	1.00	1.00	1.00	1.00	1.00	1.00	1.00	1.00	

MECHANICAL ANCHORS

POWER-STUD® + SD1
Wedge Expansion Anchor

Ultimate and Allowable Load Capacities in Tension for Power-Stud+ SD1 in Grout Filled Concrete Masonry Wall Faces^{1,2,3,4,5,6,7,8}

CODE LISTED
ICC-ES ESR-2966



Nominal Anchor Diameter d in.	Installation Torque T _{inst} ft-lbf (N-m)	Min. Embed. Depth h _{nom} in. (mm)	Min. Edge Distance in. (mm)	Min. End Distance in. (mm)	Grout-Filled Concrete Masonry			
					f'm = 1,500 psi		f'm = 2,000 psi	
					Ultimate Load Tension lbs. (kN)	Allowable Load Tension lbs. (kN)	Ultimate Load Tension lbs. (kN)	Allowable Load Tension lbs. (kN)
1/4	4 (6)	1-3/4 (45)	3 (76)	3 (76)	985 (4.4)	195 (0.9)	1,075 (4.8)	215 (1.0)
3/8	20 (27)	2-3/8 (60)	4 (102)	4 (102)	2,225 (10.0)	445 (2.0)	2,670 (12.0)	535 (2.4)
1/2	40 (54)	2-1/2 (64)	4 (102)	4 (102)	2,650 (11.9)	530 (2.4)	3,180 (14.3)	635 (2.9)
5/8	50 (68)	3-3/8 (86)	4 (102)	4 (102)	3,525 (15.9)	705 (3.2)	4,230 (19.0)	845 (3.8)
3/4	80 (108)	3-3/8 (86)	12 (305)	12 (305)	7,575 (33.7)	1,515 (6.7)	8,175 (36.4)	1,635 (7.3)
			20 (508)	20 (508)	7,575 (33.7)	1,515 (6.7)	8,175 (36.4)	1,635 (7.3)
		4-3/4 (121)	12 (305)	12 (305)	7,580 (34.1)	1,515 (6.8)	8,755 (39.4)	1,750 (7.9)

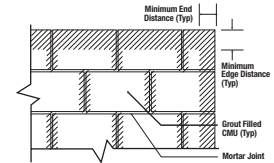

Wall Face Permissible Anchor Locations (Un-hatched Area)

1. Tabulated load values for 1/4", 3/8", 1/2" and 5/8" diameter anchors are installed in minimum 6" wide, Grade N, Type II, lightweight, medium-weight or normal-weight concrete masonry units conforming to ASTM C90. Mortar must be Type N, S or M. Masonry compressive strength must be at specified minimum at the time of installation.
2. Tabulated load values for 3/4" diameter anchors are installed in minimum 8" wide, Grade N, Type II, lightweight, medium-weight or normal-weight concrete masonry units conforming to ASTM C90. Mortar must be Type N, S or M. Masonry compressive strength must be at specified minimum at the time of installation.
3. Allowable load capacities listed are calculated using an applied safety factor of 5.0.
4. The tabulated values are applicable for anchors installed into grouted masonry wall faces at a critical spacing distance, s_{cr} , between anchors of 16 times the anchor diameter. The spacing distance between two anchors may be reduced to minimum distance, s_{min} , of 8 times the anchor diameter provided the allowable tension loads are multiplied by a reduction factor 0.80 and allowable shear loads are multiplied by a reduction factor of 0.90. Linear interpolation for calculation of allowable loads may be used for intermediate anchor spacing distances.
5. Anchors may be installed in the grouted cells and in cell webs and bed joints not closer than 1-3/8" from head joints. The minimum edge and end distances must also be maintained.
6. Allowable tension values for anchors installed into bed joints of grouted masonry wall faces with a minimum of 12" edge distance and end distance may be increased by 20 percent for the 1/2-inch diameter and 10 percent for the 5/8-inch diameter.
7. The edge and end distance is measured from the anchor centerline to the closest unrestrained edge and end of the grouted CMU block, respectively.
8. The tabulated allowable load capacities for 1/4-inch and 3/4-inch-diameter anchors in grout-filled concrete masonry units are not included in the scope of ESR-2966.

Ultimate and Allowable Load Capacities in Shear for Power-Stud+ SD1 in Grout Filled Concrete Masonry Wall Faces^{1,2,3,4,5,6,7}

CODE LISTED
ICC-ES ESR-2966



Nominal Anchor Diameter d in.	Installation Torque T _{inst} ft-lbf (N-m)	Min. Embed. Depth h _{nom} in. (mm)	Min. Edge Distance in. (mm)	Min. End Distance in. (mm)	Direction of Loading	Grout-Filled Concrete Masonry			
						f'm = 1,500 psi		f'm = 2,000 psi	
						Ultimate Load Shear lbs. (kN)	Allowable Load Shear lbs. (kN)	Ultimate Load Shear lbs. (kN)	Allowable Load Shear lbs. (kN)
1/4	4 (6)	1-3/4 (45)	3 (76)	3 (76)	Perpendicular or parallel to wall edge or end	900 (4.0)	180 (0.8)	980 (4.4)	170 (0.8)
3/8	20 (27)	2-3/8 (60)	4 (102)	4 (102)	Perpendicular or parallel to wall edge or end	2,975 (13.4)	595 (2.7)	3,570 (16.1)	715 (3.2)
1/2	40 (54)	2-1/2 (64)	4 (102)	12 (305)	Perpendicular or parallel to wall edge or end	2,800 (12.6)	560 (2.5)	3,360 (15.1)	670 (3.0)
			12 (305)	4 (102)	Parallel to wall end	4,025 (18.1)	805 (3.6)	4,830 (21.7)	965 (4.3)
			4 (102)	12 (305)	Parallel to wall edge				
5/8	50 (68)	3-3/8 (86)	4 (102)	4 (102)	Perpendicular or parallel to wall edge or end	3,425 (15.4)	685 (3.1)	4,110 (18.5)	820 (3.7)
			12 (305)	4 (102)	Parallel to wall end	5,325 (24.0)	1,065 (4.8)	6,390 (28.8)	1,280 (5.8)
			4 (102)	12 (305)	Parallel to wall edge				
3/4	80 (108)	3-3/8 (86)	12 (305)	12 (305)	Perpendicular or parallel to wall edge or end	8,850 (39.4)	1,770 (7.9)	9,375 (41.7)	1,875 (8.3)
			20 (508)	20 (508)		10,200 (45.4)	2,040 (9.1)	10,800 (48.0)	2,160 (9.6)
		4-3/4 (121)	12 (305)	12 (305)		12,735 (56.7)	2,545 (11.3)	12,735 (56.7)	2,545 (11.3)

1. Tabulated load values for 1/4", 3/8", 1/2" and 5/8" diameter anchors are installed in minimum 6" wide, Grade N, Type II, lightweight, medium-weight or normal-weight concrete masonry units conforming to ASTM C90. Mortar must be Type N, S or M. Masonry compressive strength must be at specified minimum at the time of installation.
2. Tabulated load values for 3/4" diameter anchors are installed in minimum 8" wide, Grade N, Type II, lightweight, medium-weight or normal-weight concrete masonry units conforming to ASTM C90. Mortar must be Type N, S or M. Masonry compressive strength must be at specified minimum at the time of installation.
3. Allowable load capacities listed are calculated using an applied safety factor of 5.0.
4. The tabulated values are applicable for anchors installed into grouted masonry wall faces at a critical spacing distance, s_{cr} , between anchors of 16 times the anchor diameter. The spacing distance between two anchors may be reduced to minimum distance, s_{min} , of 8 times the anchor diameter provided the allowable tension loads are multiplied by a reduction factor 0.80 and allowable shear loads are multiplied by a reduction factor of 0.90. Linear interpolation for calculation of allowable loads may be used for intermediate anchor spacing distances.
5. Anchors may be installed in the grouted cells and in cell webs and bed joints not closer than 1-3/8" from head joints. The minimum edge and end distances must also be maintained.
6. The edge and end distance is measured from the anchor centerline to the closest unrestrained edge and end of the grouted CMU block, respectively.
7. The tabulated allowable load capacities for 1/4-inch and 3/4-inch-diameter anchors in grout-filled concrete masonry units are not included in the scope of ESR-2966.

Ultimate and Allowable Load Capacities in Tension for Power-Stud+ SD1 in the Tops of Grout Filled Concrete Masonry Walls^{1,2,3,4,5,6}

CODE LISTED
ICC-ES ESR-2966



Nominal Anchor Diameter d in.	Installation Torque T _{inst} ft-lbf (N-m)	Minimum Embed. Depth h _{nom} in. (mm)	Min. Edge Distance in. (mm)	Min. End Distance in. (mm)	Grout-Filled Concrete Masonry			
					f'm = 1,500 psi		f'm = 2,000 psi	
					Ultimate Load Tension lbs. (kN)	Allowable Load Tension lbs. (kN)	Ultimate Load Tension lbs. (kN)	Allowable Load Tension lbs. (kN)
1/4	4 (6)	1-3/4 (45)	1-1/2 (38)	4 (102)	775 (3.4)	155 (0.7)	845 (3.8)	170 (0.8)
3/8	20 (27)	2-3/8 (60)	1-3/4 (45)	12 (305)	1,475 (6.6)	295 (1.3)	1,770 (8.0)	355 (1.6)
1/2	40 (54)	2-1/2 (64)	2-1/4 (57)		2,225 (9.9)	445 (2.0)	2,575 (11.5)	515 (2.3)
		5 (127)			3,425 (15.4)	685 (3.1)	4,110 (18.5)	820 (3.7)
5/8	50 (68)	3-3/8 (86)	2-1/4 (57)	3,825 (17.2)	765 (3.4)	4,590 (20.7)	920 (4.1)	
		6-1/4 (159)		3,825 (17.2)	765 (3.4)	4,590 (20.7)	920 (4.1)	

Minimum End Distance (Typ)

Minimum Edge Distance (Typ)

Top of Wall

1. Tabulated load values are for anchors installed in minimum 6" wide, minimum Grade N, Type II, lightweight, medium-weight or normal-weight concrete masonry units conforming to ASTM C90. Mortar must be Type N, S or M. Masonry compressive strength must be at the specified minimum at the time of installation.
2. Allowable load capacities listed are calculated using an applied safety factor of 5.0. Consideration of safety factors of 10 or higher may be necessary depending upon the application such as life safety.
3. Anchors must be installed in the grouted cells and the minimum edge and end distances must be maintained. Spacing distance is measured from the centerline to centerline between two anchors.
4. The tabulated values are applicable for anchors installed in top of grouted masonry walls at a critical spacing distance, s_c, between anchors of 16 times the anchor diameter.
5. The edge and end distance is measured from the anchor centerline to the closest unrestrained edge and end of the grouted CMU block, respectively.
6. The tabulated allowable load capacities for anchors with 1/4-inch-diameter, 1/2-inch diameter with 5 inch embedment and 5/8-inch diameter with 6-1/4" embedment in grout-filled concrete masonry units are not included in the scope of ESR-2966.

Ultimate and Allowable Load Capacities in Shear for Power-Stud+ SD1 in Grout Filled the Tops of Concrete Masonry Walls^{1,2,3,4,5,6}

CODE LISTED
ICC-ES ESR-2966



Nominal Anchor Diameter d in.	Installation Torque T _{inst} ft-lbf (N-m)	Minimum Embed. Depth h _{nom} in. (mm)	Min. Edge Distance in. (mm)	Min. End Distance in. (mm)	Direction of Shear Loading	Grout-Filled Concrete Masonry			
						f'm = 1,500 psi		f'm = 2,000 psi	
						Ultimate Load Shear lbs. (kN)	Allowable Load Shear lbs. (kN)	Ultimate Load Shear lbs. (kN)	Allowable Load Shear lbs. (kN)
1/4	4 (6)	1-3/4 (45)	1-1/2 (38)	4 (102)	Any	715 (3.2)	145 (0.6)	780 (3.5)	155 (0.7)
3/8	20 (27)	2-3/8 (60)	1-3/4 (45)	12 (305)	Perpendicular to wall toward minimum edge	1,150 (5.2)	230 (1.0)	1,380 (6.2)	275 (1.2)
					Parallel to wall edge	2,425 (10.9)	485 (2.2)	2,910 (13.1)	580 (2.6)
1/2	40 (54)	2-1/2 (64)	2-1/4 (57)	12 (305)	Any	1,150 (5.2)	230 (1.0)	1,380 (6.2)	275 (1.2)
		5 (127)			Perpendicular to wall toward minimum edge	1,400 (6.3)	280 (1.3)	1,680 (7.6)	325 (1.5)
					Parallel to wall edge	2,825 (12.7)	565 (2.5)	3,390 (15.3)	680 (3.1)
5/8	50 (68)	3-3/8 (86)	2-1/4 (57)	12 (305)	Any	1,150 (5.2)	230 (1.0)	1,380 (6.2)	275 (1.2)
		6-1/4 (159)			Perpendicular to wall toward minimum edge	1,700 (7.7)	340 (1.5)	2,040 (9.2)	410 (1.8)
					Parallel to wall edge	3,525 (15.9)	705 (3.2)	4,230 (19.0)	845 (3.8)

1. Tabulated load values are for anchors installed in minimum 6-inch wide, minimum Grade N, Type II, lightweight, medium-weight or normal-weight concrete masonry units conforming to ASTM C90. Mortar must be Type N, S or M. Masonry compressive strength must be at the specified minimum at the time of installation.
2. Allowable load capacities listed are calculated using an applied safety factor of 5.0. Consideration of safety factors of 10 or higher may be necessary depending upon the application such as life safety.
3. Anchors must be installed in the grouted cells and the minimum edge and end distances must be maintained. Spacing distance is measured from the centerline to centerline between two anchors.
4. The tabulated values are applicable for anchors installed in top of grouted masonry walls at a critical spacing distance, s_c, between anchors of 16 times the anchor diameter.
5. The edge and end distance is measured from the anchor centerline to the closest unrestrained edge and end of the grouted CMU block, respectively.
6. The tabulated allowable load capacities for anchors with 1/4-inch-diameter, 1/2-inch diameter with 5 inch embedment and 5/8-inch diameter with 6-1/4" embedment in grout-filled concrete masonry units are not included in the scope of ESR-2966.

MECHANICAL ANCHORS

POWER-STUD® + SD1
Wedge Expansion Anchor

TECHNICAL GUIDE – MECHANICAL ANCHORS ©2025 DEWALT – REV F

STRENGTH DESIGN INFORMATION

Power-Stud+ SD1 Anchor Installation Specifications in Concrete

Anchor Property / Setting Information	Notation	Units	Nominal Anchor Diameter												
			1/4 inch	3/8 inch			1/2 inch	5/8 inch		3/4 inch		7/8 inch	1 inch	1-1/4 inch	
Nominal anchor diameter	d _a	in. (mm)	0.250 (6.4)	0.375(9.5)			0.500 (12.7)	0.625 (15.9)		0.750 (19.1)		0.875 (22.2)	1.00 (25.4)	1.25 (31.8)	
Minimum fixture hole clearance size	d _h	in. (mm)	5/16 (7.5)	7/16 (11.1)			9/16 (14.3)	11/16 (17.5)		13/16 (20.6)		1 (25.4)	1-1/8 (28.6)	1-3/8 (34.9)	
Nominal drill bit diameter (ANSI)	d _{bit}	in.	1/4	3/8			1/2	5/8		3/4		7/8	1	1-1/4	
Minimum nominal embedment depth	h _{nom}	in. (mm)	1-3/4 (44)	1-7/8 (48)	2-3/8 (60)	2-7/8 (73)	2-1/2 (64)	3-3/4 (95)	3-3/8 (86)	4-5/8 (117)	4 (102)	5-5/8 (143)	4-1/2 (114)	5-1/2 (140)	6-1/2 (165)
Effective embedment depth	h _{ef}	in. (mm)	1.50 (38)	1.50 (38)	2.00 (51)	2.50 (64)	2.00 (51)	3.25 (83)	2.75 (70)	4.00 (102)	3.125 (79)	4.75 (114)	3.50 (89)	4.375 (111)	5.375 (137)
Minimum hole depth	h _{hole}	in. (mm)	1-7/8 (48)	2 (51)	2-1/2 (64)	3 (76)	2-3/4 (70)	4 (102)	3-3/4 (95)	5 (127)	4-1/4 (108)	5-7/8 (149)	4-7/8 (124)	5-7/8 (149)	7-1/4 (184)
Minimum overall anchor length ²	ℓ _{anch}	in.	2-1/4	2-1/4	2-3/4	3-1/2	3-3/4	4-1/2	4-1/2	6	4-3/4	7	6	9	9
Installation torque ⁶	T _{inst}	ft.-lbf. (N-m)	4 (5)	20 (27)			40 (54)	80 (108)		110 (149)		175 (237)	225 (305)	375 (508)	
Wrench socket size	-	in.	7/16	9/16			3/4	15/16		1-1/8		1-5/16	1-1/2	1-7/8	
Hex nut height	-	in.	7/32	21/64			7/16	35/64		41/64		3/4	55/64	1-1/16	

Anchors Installed in Concrete

Minimum member thickness	h _{min}	in. (mm)	3-1/4 (83)	3-1/4 (83)	3-3/4 (95)	4 (102)	5 (127)	4 (102)	6 (152)	5 (127)	6 (152)	7 (178)	8 (203)	6 (152)	8 (203)	10 (254)	10 (254)	12 (305)
Minimum edge distance	C _{min}	in. (mm)	1-3/4 (44)	2-3/4 (70)	2-3/4 (70)	2-1/4 (57)	2-1/2 (64)	2-3/4 (70)	2-3/4 (70)	4 (106)	4 (106)	4-1/4 (108)	3 (76)	5 (127)	3-3/4 (95)	7 (178)	8 (203)	8 (203)
	for s ≥	in. (mm)	n/a	3-1/2 (89)	3-3/4 (95)	3-3/4 (95)	4 (102)	4 (102)	4 (102)	6 (152)	6 (152)	6 (152)	n/a	5 (127)	6 (152)	5-1/2 (140)	N/A	N/A
Minimum spacing distance	S _{min}	in. (mm)	2-1/4 (57)	2-1/2 (64)	3-1/2 (89)	2 (51)	2-1/2 (64)	2-3/4 (70)	2 (51)	3-1/2 (89)	2-3/4 (70)	4-1/4 (108)	2-1/2 (64)	4-3/4 (121)	4 (106)	6-1/2 (165)	8 (203)	8 (203)
	for s ≥	in. (mm)	N/A	3-1/2 (89)	6 (152)	3-1/2 (89)	4 (102)	4 (106)	3-1/4 (95)	5-3/4 (146)	5 (127)	N/A	4-1/4 (108)	7 (179)	6 (152)	N/A	N/A	N/A
Critical edge distance (uncracked concrete only)	C _{ac}	in. (mm)	3-1/2 (89)	7-1/2 (191)	6-1/2 (165)	6-1/2 (165)	5 (127)	8 (203)	8 (203)	7-1/2 (191)	6 (152)	10 (254)	8 (203)	11 (279)	12 (305)	11-1/2 (292)	12 (305)	20 (508)

Anchors Installed in the Topside of Concrete-filled Steel Deck Assemblies^{3,4}

Figure 1A	Minimum topping thickness	h _{min,deck}	in. (mm)	2-1/2 (64)	3-1/4 (83)	2-1/2 (64)	2-1/2 (64)	3-1/4 (83)	See Note 3	2-1/2 (64)	3-1/4 (83)	3-1/4 (83)	See Note 3	See Note 3	See Note 3	See Note 3	See Note 3	See Note 3
	Minimum edge distance	C _{min,deck,top}	in. (mm)	2-1/2 (64)	1-3/4 (44)	4 (102)	4 (102)	2-3/4 (70)		6-1/2 (165)	4-1/2 (114)	6 (152)						
	Minimum spacing distance	S _{min,deck,top}	in. (mm)	1-1/2 (38)	2-1/4 (57)	7 (178)	3-1/2 (89)	4 (102)		6-1/2 (165)	6-1/2 (165)	6 (152)						
	Critical edge distance (uncracked concrete only)	C _{ac,deck,top}	in. (mm)	3-1/2 (89)	3-1/2 (89)	4-1/2 (114)	4-1/2 (114)	6-1/2 (165)		6 (152)	6 (152)	6 (152)						
Figure 1B	Minimum topping thickness	h _{min,deck}	in. (mm)	2-1/2 (64)	2-1/2 (64)	2-1/2 (64)	See Note 3	2-1/2 (64)	3-1/4 (83)	See Note 3	See Note 3	See Note 3	See Note 3	See Note 3	See Note 3	See Note 3	See Note 3	
	Minimum edge distance	C _{min,deck,top}	in. (mm)	2-1/2 (64)	4 (102)	4 (102)		6-1/2 (165)	6 (152)									
	Minimum spacing distance	S _{min,deck,top}	in. (mm)	1-1/2 (38)	7 (178)	3-1/2 (89)		6-1/2 (165)	6 (152)									
	Critical edge distance (uncracked concrete only)	C _{ac,deck,top}	in. (mm)	3-1/2 (89)	4-1/2 (114)	4-1/2 (114)		6 (152)	6 (152)									

For SI: 1 inch = 25.4 mm, 1 ft-lbf = 1.356 N-m. N/A = Not Applicable

- The information presented in this table is to be used in conjunction with the design criteria of ACI 318-19 Chapter 17 or ACI 318-14 Chapter 17, as applicable.
- The listed minimum overall anchor length is based on anchor sizes commercially available at the time of publication compared with the requirements to achieve the minimum nominal embedment depth, nut height and washer thickness (and consideration of a possible fixture attachment, as applicable).
- The 1/4-inch, 3/8-inch, and 1/2-inch diameter anchors may be installed in the topside of uncracked concrete-filled steel deck assemblies where concrete thickness above the upper flute meets the minimum member thicknesses specified in this table. The 3/8-inch-diameter anchors with 2-7/8-inch nominal embedment and 5/8-inch through 1-1/4-inch-diameter anchors may be installed in the topside of cracked and uncracked concrete-filled steel deck assemblies where concrete thickness above the upper flute meets the minimum member thicknesses specified in this table under Anchors Installed in Concrete.
- For installations in the topside of concrete-filled steel deck assemblies, see the installation details in Figures 1A and 1B.
- For installations through the soffit of steel deck assemblies into concrete, see the design information table and the installation details in Figures 2A and 2B, as applicable.
- Additional combinations for minimum edge distance, C_{min}, and minimum spacing distance, S_{min}, may be derived by linear interpolation between the given boundary values for the anchors.

Power-Stud+ SD1 Anchor Detail

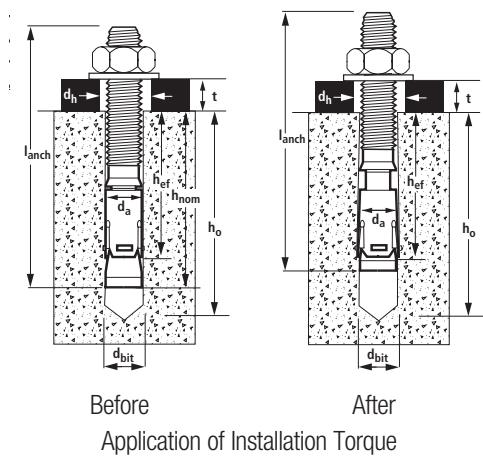

Interpolation of Minimum Edge Distance and Anchor Spacing

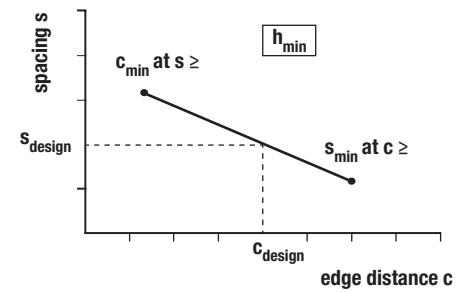

This interpolation applies to the cases when two sets of minimum edge distances, c_{min} , and minimum spacing distances, s_{min} , are given for a selected anchor diameter effective embedment depth, h_{ef} , and corresponding minimum member thickness, h_{min} .

Figure 1A - Power-Stud+ SD1 Installation Detail For Anchors In The Topside Of Concrete-Filled Steel Deck Floor And Roof Assemblies (See Dimensional Profile Requirements)¹

LIGHTWEIGHT CONCRETE OR NORMAL WEIGHT CONCRETE OVER STEEL DECK (MINIMUM 2,500 PSI)

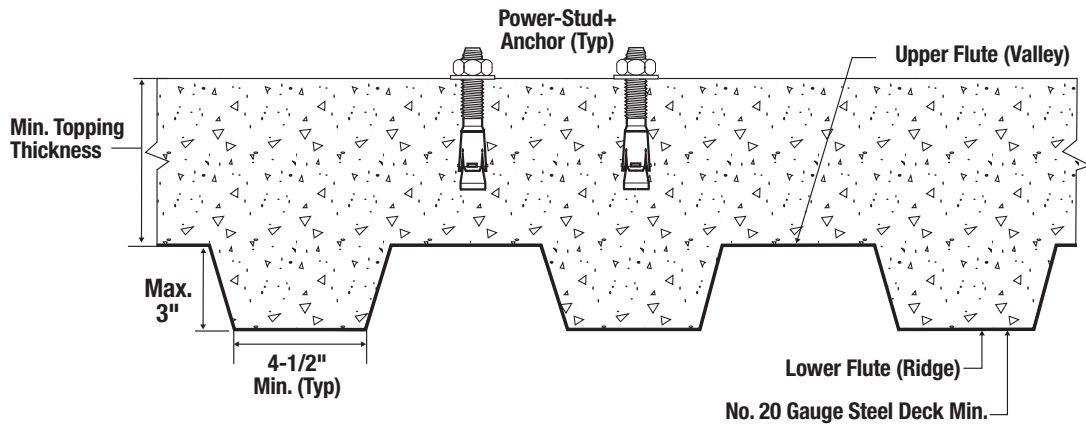

1. Anchors may be placed in the topside of steel deck profiles in accordance with Figure 1 provided the minimum member topping thickness, minimum spacing distance and minimum edge distance are satisfied as given in Installation Specifications.

Figure 1B - Power-Stud+ SD1 Installation Detail for Anchors in the Topside of Concrete-Filled Steel Deck Floor and Roof Assemblies (See Dimensional Profile Requirements)¹

LIGHTWEIGHT CONCRETE OR NORMAL WEIGHT CONCRETE OVER STEEL DECK (MINIMUM 2,500 PSI)

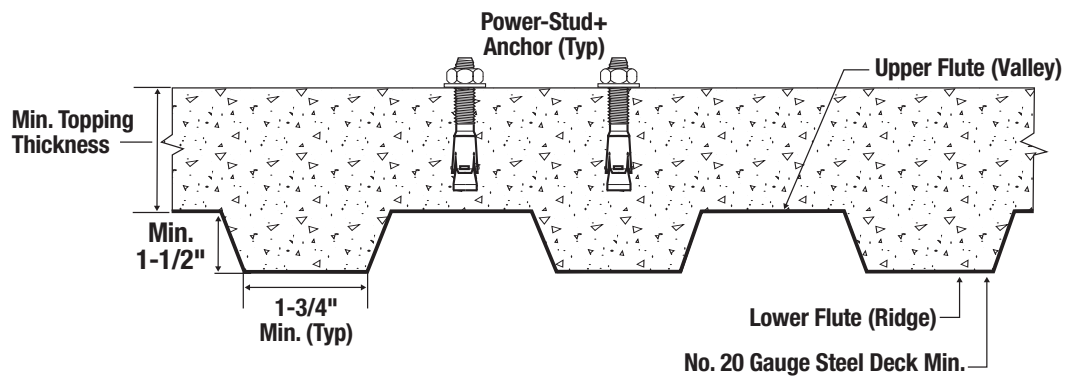

1. Anchors may be placed in the topside of steel deck profiles in accordance with Figure 1B provided the minimum member topping thickness, minimum spacing distance and minimum edge distance are satisfied as given in the Installation Specifications.

Figure 2A—Power-Stud+ SD1 Installation Detail for Anchors in the Soffit of Concrete Over Steel Deck Floor and Roof Assemblies (See Dimensional Profile Requirements)^{1,2}

SAND-LIGHTWEIGHT CONCRETE OR NORMAL WEIGHT CONCRETE OVER STEEL DECK (MINIMUM 3,000 PSI)

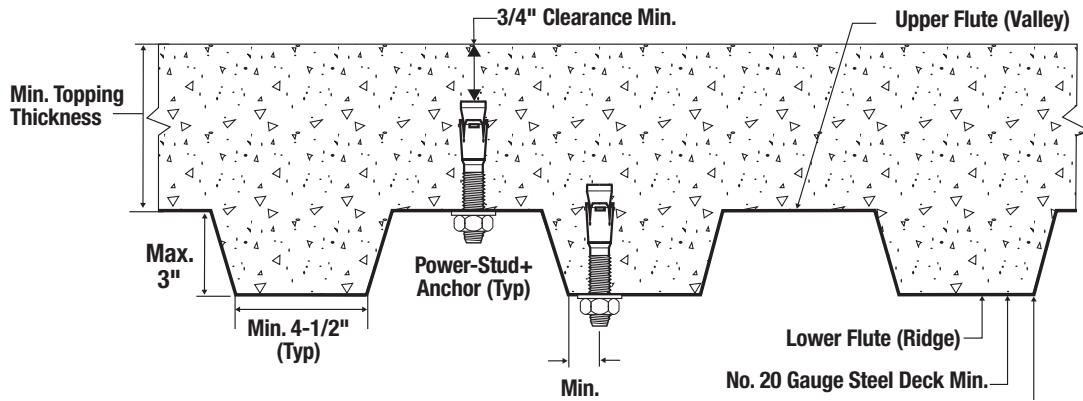

1. Anchors may be placed in the upper flute or lower flute of the steel deck profiles in accordance with Figure 2A provided the minimum hole clearance is satisfied. Anchors in the lower flute of Figure 2A profiles may be installed with a maximum 1-inch offset in either direction from the center of the flute. The off-set distance may be increased proportionally for profiles with lower flute widths greater than those shown provided the minimum lower flute edge distance is also satisfied. In addition, the anchors must have an axial spacing along the flute equal to the greater of $3h_{ef}$ or 1.5 times the flute width.
2. See design data table for this condition.

Figure 2B—Power-Stud+ SD1 Installation Detail for Anchors in the Soffit of Concrete Over Steel Deck Floor and Roof Assemblies (See Dimensional Profile Requirements)^{1,2,3}

SAND-LIGHTWEIGHT CONCRETE OR NORMAL WEIGHT CONCRETE OVER STEEL DECK (MINIMUM 3,000 PSI)

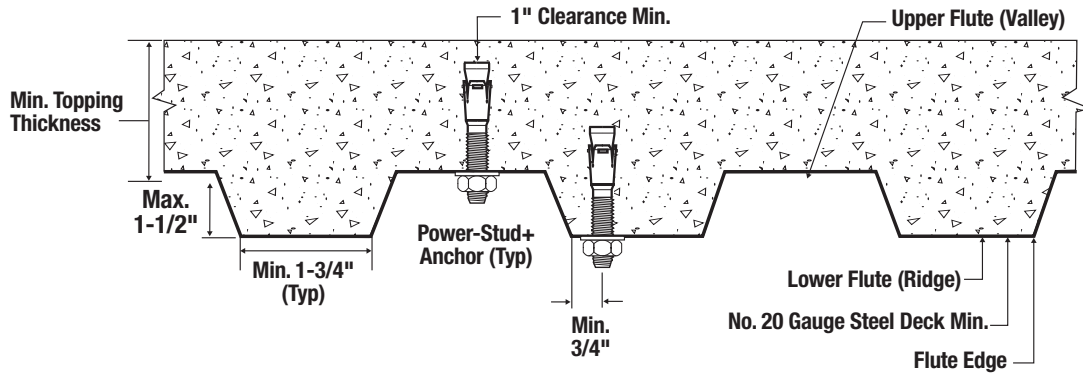

1. Anchors may be placed in the lower flute of the steel deck profiles in accordance with Figure 2B provided the minimum hole clearance is satisfied. Anchors in the lower flute of Figure 2B profiles may be installed with a maximum 1/8 inch offset in either direction from the center of the flute. The offset distance may be increased proportionally for profiles with lower flute widths greater than those shown provided the minimum lower flute edge distance is also satisfied. In addition, the anchors must have an axial spacing along the flute equal to the greater of $3h_{ef}$ or 1.5 times the flute width.
2. Anchors may be placed in the upper flute of the steel deck profiles in accordance with Figure 2B provided the concrete thickness above the upper flute is minimum 3-1/4 inch and a minimum hole clearance of 3/4 inch is satisfied.
3. See design data table for this condition.

Tension Design Information for Power-Stud+ SD1 Anchor in Concrete

CODE LISTED
ICC-ES ESR-2818



Design Characteristic	Notation	Units	Nominal Anchor Diameter												
			1/4 inch	3/8 inch		1/2 inch	5/8 inch		3/4 inch	7/8 inch	1 inch	1-1/4 inch			
Anchor category	1, 2 or 3	-	1	1		1	1		1	1	1	1			
Nominal anchor diameter	d_a	in. (mm)	0.250 (6.4)	0.375 (9.5)		0.625 (15.9)	0.750 (19.1)		0.875 (22.2)	1.000 (25.4)	1.25 (31.8)				
Nominal embedment depth	h_{nom}	in. (mm)	1-3/4 (44)	1-7/8 (48)	2-3/8 (60)	2-7/8 (73)	2-1/2 (64)	3-3/4 (95)	3-3/8 (86)	4-5/8 (117)	4 (102)	5-5/8 (143)	4-1/2 (114)	5-1/2 (140)	6-1/2 (165)
Effective embedment depth	h_{ef}	in. (mm)	1.50 (38)	1.50 (38)	2.00 (51)	2.50 (64)	2.00 (51)	3.25 (83)	2.75 (70)	4.00 (102)	3.125 (79)	4.75 (114)	3.50 (89)	4.375 (111)	5.375 (137)
STEEL STRENGTH IN TENSION (ACI 318-19 17.6.1, ACI 318-14 17.4.1)¹															
Minimum specified yield strength	f_{ya}	ksi (N/mm ²)	88.0 (606)	88.0 (606)		80.0 (551)	80.0 (551)		64.0 (441)	60.0 (414)	60.0 (414)	60.0 (414)			
Minimum specified ultimate tensile strength (neck)	f_{uta}^{12}	ksi (N/mm ²)	110.0 (758)	110.0 (758)		100.0 (689)	100.0 (689)		80.0 (552)	75.0 (517)	75.0 (517)	75.0 (517)			
Effective tensile stress area (neck)	$A_{se,N}$	in ² (mm ²)	0.0220 (14.2)	0.0531 (34.3)		0.1018 (65.7)	0.1626 (104.9)		0.2376 (150.9)	0.327 (207.5)	0.430 (273.1)	0.762 (484)			
Steel strength in tension ⁴	N_{sa}^{12}	lb (kN)	2,255 (10.0)	5,455 (24.3)		9,080 (40.4)	14,465 (64.3)		19,000 (84.5)	24,500 (109.0)	32,250 (143.5)	56,200 (250)			
Reduction factor for steel strength ³	ϕ	-	0.75												
CONCRETE BREAKOUT STRENGTH IN TENSION (ACI 318-19 17.6.2, ACI 318-14 17.4.2)¹															
Effectiveness factor for uncracked concrete	k_{uncr}	-	24	24		24	24		24	24	24	27			
Effectiveness factor for cracked concrete	k_{cr}	-	Not Applicable	17		17	17		21	17	21	24			
Modification factor for cracked and uncracked concrete ⁵	$\Psi_{c,N}$	-	1.0	1.0		1.0	1.0		1.0	1.0	1.0	1.0			
Critical edge distance (uncracked concrete only)	c_{ac}	in. (mm)	See Installation Specifications in concrete												
Reduction factor for concrete breakout strength ³	ϕ	-	0.65 (Condition B)												
PULLOUT STRENGTH IN TENSION (ACI 318-19 17.6.3, ACI 318-14 17.4.3)^{1,6}															
Characteristic pullout strength, uncracked concrete (2,500 psi) ⁶	$N_{p,uncr}$	lb (kN)	See note 7	See note 7	2,865 (12.8)	4,575 (20.4)	3,220 (14.3)	5,530 (24.6)	See note 7	See note 7	See note 7	See note 7	See note 7	See note 7	
Characteristic pullout strength, cracked concrete (2,500 psi) ⁶	$N_{p,cr}$	lb (kN)	Not Applicable	See note 7	2,035 (9.1)	2,035 (9.1)	See note 7	2,505 (11.2)	See note 7	4,450 (19.8)	See note 7	See note 7	See note 7	11,350 (50.5)	
Reduction factor for pullout strength ³	ϕ	-	0.65 (Condition B)												
PULLOUT STRENGTH IN TENSION FOR SEISMIC APPLICATIONS (ACI 318-19 17.10.3, ACI 318-14 17.2.3.3)^{8,9}															
Characteristic pullout strength, seismic (2,500 psi) ^{6,10}	$N_{p,eq}$	lb (kN)	Not Applicable	See note 7	2,035 (9.1)	2,035 (9.1)	See note 7	2,505 (11.2)	See note 7	4,450 (19.8)	See note 7	See note 7	See note 7	11,350 (50.5)	
Reduction factor for pullout strength, seismic ³	ϕ	-	0.65 (Condition B)												

For St: 1 inch = 25.4 mm; 1 ksi = 6.894 N/mm²; 1 lbf = 0.0044 kN.

- The data in this table is intended to be used with the design provisions of ACI 318 (-19 or -14) Chapter 17, as applicable; for anchors resisting seismic load combinations the additional requirements of ACI 318-19 17.10, ACI 318-14 17.2.3, as applicable, must apply.
- Installation must comply with published instructions and details.
- All values of ϕ apply to the load combinations of IBC Section 1605.2, ACI 318 (-19 or -14) Section 5.3, as applicable. For reinforcement that meets ACI 318 (-19 or -14) Chapter 17 requirements for Condition A, see ACI 318-19 17.5.3, ACI 318-14 17.3.3(c), as applicable, for the appropriate ϕ factor when the load combinations of IBC Section 1605.2, ACI 318 (-19 or -14) Section 5.3, as applicable, are used.
- The Power-Stud+ SD1 is considered a ductile steel element as defined by ACI 318 (-19 or -14) 2.3 as applicable. Tabulated values for steel strength in tension are based on test results per ACI 355.2 and must be used for design.
- For all design cases use $\Psi_{c,N} = 1.0$. The appropriate effectiveness factor for cracked concrete (k_{cr}) or uncracked concrete (k_{uncr}) must be used.
- For all design cases use $\Psi_{c,P} = 1.0$. For concrete compressive strength greater than 2,500 psi $N_{pn} = (\text{pullout strength from table}) \times (\text{specified concrete compressive strength} / 2,500)^{0.5}$.
- Pullout strength does not control design of indicated anchors. Do not calculate pullout strength for indicated anchor size and embedment.
- Anchors are permitted to be used in lightweight concrete provided the modification factor λ_a equal to 0.8λ is applied to all values of $\sqrt{f'_c}$ affecting N_n and V_n . λ shall be determined in accordance with the corresponding version of ACI 318.
- For anchors in the topside of concrete-filled steel deck assemblies, see Figure 1A and 1B, as applicable.
- Tabulated values for characteristic pullout strength in tension are for seismic applications and based on test results in accordance with ACI 355.2, Section 9.5.

MECHANICAL ANCHORS

POWER-STUD® + SD1
Wedge Expansion Anchor

TECHNICAL GUIDE – MECHANICAL ANCHORS ©2025 DEWALT – REV F

Shear Design Information for Power-Stud+ SD1 Anchor in Concrete

CODE LISTED
ICC-ES ESR-2818



Design Characteristic	Notation	Units	Nominal Anchor Diameter												
			1/4 inch	3/8 inch		1/2 inch	5/8 inch		3/4 inch	7/8 inch	1 inch	1-1/4 inch			
Anchor category	1, 2 or 3	-	1	1		1	1		1	1	1	1	1		
Nominal anchor diameter	d_a	in. (mm)	0.250 (6.4)	0.375 (9.5)		0.500 (12.7)	0.625 (15.9)		0.750 (19.1)	0.875 (22.2)	1.000 (25.4)	1.25 (31.8)			
Nominal embedment depth	h_{nom}	in. (mm)	1-3/4 (44)	1-7/8 (48)	2-3/8 (60)	2-7/8 (73)	2-1/2 (64)	3-3/4 (95)	3-3/8 (86)	4-5/8 (117)	4 (102)	5-5/8 (143)	4-1/2 (114)	5-1/2 (140)	6-1/2 (165)
Effective embedment	h_{ef}	in. (mm)	1.50 (38)	1.50 (38)	2.00 (51)	2.50 (64)	2.00 (51)	3.25 (83)	2.75 (70)	4.00 (102)	3.125 (79)	4.75 (114)	3.50 (88.9)	4.375 (111)	5.375 (137)
STEEL STRENGTH IN SHEAR (ACI 318-19 17.7.1, ACI 318-14 17.5.1)¹															
Minimum specified yield strength (threads)	f_{ya}	ksi (N/mm ²)	70.0 (482)	80.0 (552)		70.4 (485)	70.4 (485)		64.0 (441)	60 (414)	60 (414)	60 (414)			
Minimum specified ultimate strength (threads)	f_{uta}	ksi (N/mm ²)	88.0 (606)	100.0 (689)		88.0 (607)	88.0 (607)		80.0 (552)	75.0 (517)	75.0 (517)	75.0 (517)			
Effective tensile stress area (threads)	$A_{se,v}$	in ² (mm ²)	0.0318 (20.5)	0.0775 (50.0)		0.1419 (91.5)	0.2260 (145.8)		0.3345 (212.4)	0.462 (293.4)	0.6060 (384.8)	0.969 (615)			
Steel strength in shear ²	V_{sa}	lb (kN)	925 (4.1)	2,330 (10.4)	2,990 (13.3)	3,185 (14.2)	4,620 (20.6)	9,030 (40.2)	10,640 (47.3)	11,655 (54.8)	8,820 (39.2)	9,845 (43.8)	17,750 (79.0)		
Reduction factor for steel strength ³	ϕ	-	0.65												
STEEL STRENGTH IN SHEAR FOR SEISMIC APPLICATIONS (ACI 318-19 17.10.1, ACI 318-14 17.2.3.3)															
Steel strength in shear, seismic ⁴	$V_{sa,eq}$	lb (kN)	N/A	2,330 (10.4)	2,440 (10.9)	3,185 (14.2)	3,960 (17.6)	6,000 (26.7)	8,580 (38.2)	9,635 (42.9)	8,820 (39.2)	9,845 (43.8)	17,750 (79.0)		
Reduction factor for steel strength in shear for seismic ³	ϕ	-	0.65												
CONCRETE BREAKOUT STRENGTH IN SHEAR (ACI 318-19 17.7.2, ACI 318-14 17.5.2)^{5,7}															
Load bearing length of anchor	ℓ_e	in. (mm)	1.50 (38)	1.50 (38)	2.00 (51)	2.50 (64)	2.00 (51)	3.25 (83)	2.75 (70)	4.00 (102)	3.125 (79)	4.75 (114)	3.50 (88.9)	4.375 (111)	5.375 (137)
Nominal anchor diameter	d_a	in. (mm)	0.250 (6.4)	0.375 (9.5)		0.500 (12.7)		0.625 (15.9)		0.750 (19.1)		0.875 (22.2)	1.000 (25.4)	1.25 (31.8)	
Reduction factor for concrete breakout ³	ϕ	-	0.70 (Condition B)												
PRYOUT STRENGTH IN SHEAR (ACI 318-19 17.7.3, ACI 318-14 17.2.3.3)^{6,7}															
Coefficient for pryout strength	k_{cp}	-	1.0	1.0	1.0	2.0	1.0	2.0	2.0	2.0	2.0	2.0	2.0	2.0	2.0
Reduction factor for pryout strength ³	ϕ	-	0.70 (Condition B)												
<p>For SI: 1 inch = 25.4 mm; 1 ksi = 6.894 N/mm²; 1 lbf = 0.0044 kN.</p> <ol style="list-style-type: none"> The data in this table is intended to be used with the design provisions of ACI 318 (-19 or -14) Chapter 17, as applicable; for anchors resisting seismic load combinations the additional requirements of ACI 318-19 17.10, ACI 318-14 17.2.3, as applicable, must apply. Installation must comply with published instructions and details. All values of ϕ were determined from the load combinations of IBC Section 1605.2, ACI 318 (-19 or -14) Section 5.3. For reinforcement that meets ACI 318 (-19 or -14) Chapter 17 requirements for Condition A, see ACI 318-19 17.5.3, ACI 318-14 17.3.3(c), as applicable, for the appropriate ϕ factor when the load combinations of IBC Section 1605.2, ACI 318-14 Section 5.3, as applicable, are used. The Power-Stud+ SD1 is considered a ductile steel element as defined by ACI 318 (-19 or -14) 2.3, as applicable. Tabulated values for steel strength in shear must be used for design. Anchors are permitted to be used in lightweight concrete provided the modification factor λ_a equal to 0.8λ is applied to all values of $\sqrt{f'_c}$ affecting N_n and V_n. λ shall be determined in accordance with the corresponding version of ACI 318. For anchors in the topside of concrete-filled steel deck assemblies, see Figure 1A and 1B, as applicable. Tabulated values for steel strength in shear are for seismic applications and based on test results in accordance with ACI 355.2, Section 9.6. 															

MECHANICAL ANCHORS

POWER-STUD[®] + SD1
Wedge Expansion Anchor

**Tension and Shear Design Information for Power-Stud+ SD1 Anchor in the Soffit
(Through the Underside) of Concrete-Filled Steel Deck Assemblies^{1,10,11}**

Anchor Property / Setting Information	Notation	Units	Nominal Anchor Diameter										
			1/4 inch	3/8 inch		1/2 inch		5/8 inch	3/4 inch				
Anchor category	1, 2 or 3	-	1	1		1		1	1		1		
Nominal anchor diameter	d_a	in. (mm)	0.250 (6.4)	0.375 (9.5)		0.500 (12.7)		0.625 (15.9)	0.750 (19.1)		0.750 (19.1)		
Nominal embedment depth	h_{nom}	in. (mm)	1-3/4 (44)	2-3/8 (60)	2-7/8 (73)	2-1/2 (64)	2-3/4 (95)	3-3/8 (86)	4 (102)		4 (102)		
Effective embedment	h_{ef}	in. (mm)	1.50 (38)	2.00 (51)	2.50 (64)	2.00 (51)	3.25 (83)	2.75 (70)	3.125 (79)		3.125 (79)		
See Figure 2A: Minimum 4-1/2-inch-wide Deck Flute													
Minimum yield strength of steel deck ⁹	-	ksi	50	50	33	50	50	33	50	50	33	50	33
Minimum concrete topping thickness	$h_{min,deck,top}$	in. (mm)	2-1/2 (64)	2-1/2 (64)	3-1/4 (83)	2-1/2 (64)	2-1/2 (64)	3-1/4 (83)	2-1/2 (64)	2-1/2 (64)	3-1/4 (83)	2-1/2 (64)	3-1/4 (83)
Pullout strength, uncracked concrete (3,000 psi) ⁴	$N_{p,deck,uncr}$	lb (kN)	1,195 (5.3)	2,320 (10.3)	1,940 (8.6)	2,320 (10.3)	2,760 (12.3)	3,205 (14.2)	4,135 (18.4)	3,310 (14.7)	2,795 (12.4)	4,280 (19.0)	3,230 (14.4)
Pullout strength, cracked concrete (3,000 psi) ⁴	$N_{p,deck,cr}$	lb (kN)	N/A	1,645 (7.3)	1,375 (6.1)	1,645 (7.3)	2,060 (9.2)	2,390 (10.6)	3,085 (13.7)	2,345 (10.4)	1,980 (8.8)	3,745 (16.7)	2,825 (12.4)
Pullout strength, seismic (3,000 psi) ⁵	$N_{p,deck,eq}$	lb (kN)	N/A	1,645 (7.3)	1,375 (6.1)	1,645 (7.3)	2,060 (9.2)	2,390 (10.6)	3,085 (13.7)	2,345 (10.4)	1,980 (8.8)	3,745 (16.7)	2,825 (12.4)
Reduction factor, pullout strength ²	ϕ	-	0.65 (Condition B, supplementary reinforcement not present)										
Steel strength in shear ^{6,7,8}	$V_{sa,deck}$	lb (kN)	1,450 (6.5)	3,100 (13.8)	2,120 (9.4)	3,100 (13.8)	3,235 (14.4)	2,290 (10.2)	5,145 (22.9)	3,360 (14.9)	3,710 (16.5)	4,520 (20.1)	5,505 (24.5)
Steel strength in shear, seismic ^{6,7,8}	$V_{sa,deck,eq}$	lb (kN)	N/A	3,100 (13.8)	2,120 (9.4)	3,100 (13.8)	3,235 (14.4)	2,290 (10.2)	5,145 (22.9)	3,360 (14.9)	3,710 (16.5)	4,520 (20.1)	5,505 (24.5)
Reduction factor, steel strength, shear ²	ϕ	-	0.65										
See Figure 2A: Minimum 1-3/4-inch-wide Deck Flute													
Minimum yield strength of steel deck ⁹	-	ksi	N/A	33		33	50	50	N/A	N/A		N/A	N/A
Minimum concrete topping thickness	$h_{min,deck,top}$	in. (mm)	N/A	2-1/4 (57)		2-1/4 (57)	3-1/4 (83)	3-1/4 (83)	N/A	N/A		N/A	N/A
Pullout strength, uncracked concrete (3,000 psi) ⁴	$N_{p,deck,uncr}$	lb (kN)	N/A	1,665 (7.4)		1,900 (8.5)	4,250 (18.9)	4,695 (20.9)	N/A	N/A		N/A	N/A
Pullout strength, cracked concrete (3,000 psi) ⁴	$N_{p,deck,cr}$	lb (kN)	N/A	1,180 (5.2)		1,420 (6.3)	3,170 (14.1)	3,325 (14.8)	N/A	N/A		N/A	N/A
Pullout strength, seismic (3,000 psi) ⁵	$N_{p,deck,eq}$	lb (kN)	N/A	1,180 (5.2)		1,420 (6.3)	3,170 (14.1)	3,325 (14.8)	N/A	N/A		N/A	N/A
Reduction factor, pullout strength ²	ϕ	-	N/A	0.65 (Condition B, supplementary reinforcement not present)						N/A	N/A		
Steel strength in shear ^{6,7,8}	$V_{sa,deck}$	lb (kN)	N/A	2,120 (9.4)		2,785 (12.4)	4,520 (20.1)	3,000 (13.3)	N/A	N/A		N/A	N/A
Steel strength in shear, seismic ^{6,7,8}	$V_{sa,deck,eq}$	lb (kN)	N/A	2,120 (9.4)		2,785 (12.4)	4,520 (20.1)	3,000 (13.3)	N/A	N/A		N/A	N/A
Reduction factor, steel strength, shear ²	ϕ	-	N/A	0.65						N/A	N/A		

For St: 1 inch = 25.4 mm, 1 ft-lb = 1.356 N-m, 1 psi = 0.0069 N/mm² (MPa). N/A = Not Applicable.

- Installation must comply with manufacturer's published installation instructions and details.
- The strength reduction factor applies when the load combinations from the ACI 318-19 or ACI 318-14 are used and the requirements of ACI 318-19 17.5.3 or ACI 318-14 17.3.3 are met.
- For concrete compressive strength greater than 3,000 psi, $N_{p,cr}$ = (pullout strength from table)*(specified concrete compressive strength/3,000)^{0.5}.
- Values for $N_{p,deck}$ and $N_{p,deck,cr}$ are for normal-weight or sand-lightweight concrete ($f'_c, min = 3,000$ psi); additional lightweight concrete reduction factors need not be applied. In addition, evaluation for the concrete breakout capacity in accordance with ACI 318-19 17.6.2 or ACI 318-14 17.4.2, is not required for anchors installed in the deck soffit (through underside).
- Values for $N_{p,deck,eq}$ are applicable for seismic loading and may be adjusted for the specified concrete compressive strength.
- Shear loads for anchors installed through steel deck into concrete may be applied in any direction.
- Tabulated values for $V_{sa,deck}$ and $V_{sa,deck,eq}$ are for sand-lightweight concrete or normal-weight concrete ($f'_c, min = 3,000$ psi); additional lightweight concrete reduction factors need not be applied, as applicable. In addition, evaluation for the concrete breakout capacity in accordance with ACI 318-19 17.7.2 or ACI 318-14 17.5.2 and the pryout capacity in accordance with ACI 318-19 17.7.3 or ACI 318-14 17.5.3 are not required for anchors installed in the deck soffit (flute).
- Shear loads for anchors installed through steel deck into concrete may be applied in any direction.
- Steel deck complying with ASTM A653/A653M SS Grade 33 or Grade 55, with a minimum yield strength of 33 ksi (228 MPa) or 50 ksi (345 MPa) respectively; values provided for reference.
- For installation of 5/8-inch-diameter anchors through the soffit of the steel deck into concrete, the installation torque is 50 ft.-lb. For installation of 3/4-inch-diameter anchors through the soffit of the steel deck into concrete, installation torque is 80 ft.-lb.
- In accordance with the figures, anchors installed through the soffit of steel deck assemblies into concrete must have a minimum axial spacing along the flute equal to the greater of $3h_{ef}$ or 1.5 times the flute width.

DESIGN STRENGTH TABLES (SD)

Tension and Shear Design Strengths for Power-Stud+ SD1 in Cracked Concrete^{1,2,3,4,5,6,7}



Nominal Anchor Diameter (in.)	Nominal Embed. h_{nom} (in.)	Minimum Concrete Compressive Strength									
		$f'_c = 2,500$ psi		$f'_c = 3,000$ psi		$f'_c = 4,000$ psi		$f'_c = 6,000$ psi		$f'_c = 8,000$ psi	
		ϕN_n Tension (lbs.)	ϕV_n Shear (lbs.)	ϕN_n Tension (lbs.)	ϕV_n Shear (lbs.)	ϕN_n Tension (lbs.)	ϕV_n Shear (lbs.)	ϕN_n Tension (lbs.)	ϕV_n Shear (lbs.)	ϕN_n Tension (lbs.)	ϕV_n Shear (lbs.)
3/8	1-7/8	1,015	1,095	1,110	1,195	1,285	1,385	1,570	1,515	1,815	1,515
	2-3/8	1,325	1,685	1,450	1,845	1,675	1,945	2,050	1,945	2,365	1,945
	2-7/8	1,325	2,000	1,450	2,070	1,675	2,070	2,050	2,070	2,365	2,070
1/2	2-1/2	1,565	1,685	1,710	1,845	1,975	2,130	2,420	2,605	2,795	3,005
	3-3/4	1,630	3,005	1,785	3,005	2,060	3,005	2,520	3,005	2,915	3,005
5/8	3-3/8	2,520	3,565	2,760	3,905	3,185	4,510	3,905	5,525	4,505	5,870
	4-5/8	2,895	5,870	3,170	5,870	3,660	5,870	4,480	5,870	5,175	5,870
3/4	4	3,770	6,210	4,130	6,800	4,770	6,915	5,840	6,915	6,745	6,915
	5-5/8	5,720	7,575	6,265	7,575	7,235	7,575	8,860	7,575	10,230	7,575
7/8	4-1/2	4,470	5,735	4,895	5,735	5,655	5,735	6,925	5,735	7,995	5,735
1	5-1/2	7,140	7,110	7,820	7,110	9,030	7,110	11,060	7,110	12,770	7,110
1-1/4	6-1/2	7,380	11,540	8,080	11,540	9,330	11,540	11,430	11,540	13,195	11,540

■ - Anchor Pullout/Pryout Strength Controls ■ - Concrete Breakout Strength Controls ■ - Steel Strength Controls

Tension and Shear Design Strengths for Power-Stud+ SD1 in Uncracked Concrete^{1,2,3,4,5,6}

Nominal Anchor Diameter (in.)	Nominal Embed. h_{nom} (in.)	Minimum Concrete Compressive Strength									
		$f'_c = 2,500$ psi		$f'_c = 3,000$ psi		$f'_c = 4,000$ psi		$f'_c = 6,000$ psi		$f'_c = 8,000$ psi	
		ϕN_n Tension (lbs.)	ϕV_n Shear (lbs.)	ϕN_n Tension (lbs.)	ϕV_n Shear (lbs.)	ϕN_n Tension (lbs.)	ϕV_n Shear (lbs.)	ϕN_n Tension (lbs.)	ϕV_n Shear (lbs.)	ϕN_n Tension (lbs.)	ϕV_n Shear (lbs.)
3/8	1-7/8	1,015	1,095	1,110	1,195	1,285	1,385	1,570	1,515	1,815	1,515
	2-3/8	1,325	1,685	1,450	1,845	1,675	1,945	2,050	1,945	2,365	1,945
	2-7/8	1,325	2,000	1,450	2,070	1,675	2,070	2,050	2,070	2,365	2,070
1/2	2-1/2	1,565	1,685	1,710	1,845	1,975	2,130	2,420	2,605	2,795	3,005
	3-3/4	1,630	3,005	1,785	3,005	2,060	3,005	2,520	3,005	2,915	3,005
5/8	3-3/8	2,520	3,565	2,760	3,905	3,185	4,510	3,905	5,525	4,505	5,870
	4-5/8	2,895	5,870	3,170	5,870	3,660	5,870	4,480	5,870	5,175	5,870
3/4	4	3,770	6,210	4,130	6,800	4,770	6,915	5,840	6,915	6,745	6,915
	5-5/8	5,720	7,575	6,265	7,575	7,235	7,575	8,860	7,575	10,230	7,575
7/8	4-1/2	4,470	5,735	4,895	5,735	5,655	5,735	6,925	5,735	7,995	5,735
1	5-1/2	7,140	7,110	7,820	7,110	9,030	7,110	11,060	7,110	12,770	7,110
1-1/4	6-1/2	7,380	11,540	8,080	11,540	9,330	11,540	11,430	11,540	13,195	11,540

■ - Anchor Pullout/Pryout Strength Controls ■ - Concrete Breakout Strength Controls ■ - Steel Strength Controls

- Tabular values are provided for illustration and are applicable for single anchors installed in normal-weight concrete with minimum slab thickness, $h_a = h_{min}$, and with the following conditions:
 - C_{a1} is greater than or equal to the critical edge distance, C_{ac} (table values based on $C_{a1} = C_{ac}$).
 - C_{a2} is greater than or equal to 1.5 times C_{a1} .
- Calculations were performed according to ACI 318 (-19 or -14) Chapter 17. The load level corresponding to the controlling failure mode is listed. (e.g. For tension: steel, concrete breakout and pullout; For shear: steel, concrete breakout and pryout). Furthermore, the capacities for concrete breakout strength in tension and pryout strength in shear are calculated using the effective embedment values, h_{ef} , for the selected anchors as noted in the design information tables. Please also reference the installation specifications for more information.
- Strength reduction factors (ϕ) were based on ACI 318 (-19 or -14) Section 5.3 for load combinations. Condition B is assumed.
- Tabular values are permitted for static loads only, seismic loading is not considered with these tables.
- For designs that include combined tension and shear, the interaction of tension and shear loads must be calculated in accordance with ACI 318 (-19 or -14) Chapter 17.
- Interpolation is not permitted to be used with the tabular values. For intermediate base material compressive strengths please see ACI 318 (-19 or -14) Chapter 17. For other design conditions including seismic considerations please see ACI 318 (-19 or -14) Chapter 17.
- For seismic design of anchors installed in regions designated as Seismic Design Categories C, D, E or F and in accordance with ACI 318, the tabulated tension design strengths in cracked concrete for concrete breakout and pullout strength must be multiplied by a factor of 0.75.

ORDERING INFORMATION

MECHANICAL ANCHORS

POWER-STUD® + SD1
Wedge Expansion Anchor

TECHNICAL GUIDE – MECHANICAL ANCHORS ©2025 DEWALT – REV F

Power-Stud+ SD1 (Carbon Steel Body and Expansion Clip)

Cat. No.	Made in USA Cat. No.	Anchor Size	Approx. Thread Length	Pack Qty.	Carton Qty.	Suggested ANSI Carbide Drill Bit (Cat. No.)				
						Full Head SDS-Plus	SDS-Plus	SDS-Max	Hollow Bit SDS-Plus	Hollow Bit SDS-Max
7400SD1-PWR	7400SD1USA-PWR	1/4" x 1-3/4"	3/4"	100	600	DW5517	DW5416	-	-	-
7402SD1-PWR	7402SD1USA-PWR	1/4" x 2-1/4"	1-1/4"	100	600	DW5517	DW5417	-	-	-
7404SD1-PWR	7404SD1USA-PWR	1/4" x 3-1/4"	2-1/4"	100	600	DW5517	DW5417	-	-	-
7410SD1-PWR	7410SD1USA-PWR	3/8" x 2-1/4"	7/8"	50	300	DW5527	DW5427	-	-	-
7412SD1-PWR	7412SD1USA-PWR	3/8" x 2-3/4"	1-3/8"	50	300	DW5527	DW5427	-	-	-
7413SD1-PWR	7413SD1USA-PWR	3/8" x 3"	1-5/8"	50	300	DW5527	DW5427	-	-	-
7414SD1-PWR	-	3/8" x 3-1/2"	2-1/8"	50	300	DW5527	DW5427	-	-	-
7415SD1-PWR	7415SD1USA-PWR	3/8" x 3-3/4"	2-3/8"	50	300	DW5527	DW5427	-	-	-
7416SD1-PWR	7416SD1USA-PWR	3/8" x 5"	3-5/8"	50	300	DW55300	DW5429	-	-	-
7417SD1-PWR	7417SD1USA-PWR*	3/8" x 7"	5-5/8"	50	200	DW55300	DW5429	-	-	-
7420SD1-PWR	7420SD1USA-PWR	1/2" x 2-3/4"	1"	50	200	DW5537	DW5437	DW5803	DWA54012	-
7422SD1-PWR	7422SD1USA-PWR	1/2" x 3-3/4"	2"	50	200	DW5537	DW5437	DW5803	DWA54012	-
7423SD1-PWR	7423SD1USA-PWR	1/2" x 4-1/2"	2-3/4"	50	200	DW5539	DW5438	DW5803	DWA54012	-
7424SD1-PWR	7424SD1USA-PWR	1/2" x 5-1/2"	3-3/4"	50	150	DW5539	DW5438	DW5803	DWA54012	-
7426SD1-PWR	7426SD1USA-PWR	1/2" x 7"	5-1/4"	25	100	DW5539	DW5438	DW5803	DWA54012	-
7427SD1-PWR	7427SD1USA-PWR*	1/2" x 8-1/2"	6-3/4"	25	100	DW5539	DW5439	DW5804	DWA54012	-
7428SD1-PWR	-	1/2" x 10"	8-1/4"	25	100	DW5539	DW5439	DW5804	DWA54012	-
7430SD1-PWR	7430SD1USA-PWR*	5/8" x 3-1/2"	1-1/2"	25	100	-	DW5446	DW5806	DWA54058	DWA54058
7432SD1-PWR	7432SD1USA-PWR	5/8" x 4-1/2"	2-1/2"	25	100	-	DW5446	DW5806	DWA54058	DWA54058
7433SD1-PWR	7433SD1USA-PWR	5/8" x 5"	3"	25	100	-	DW5446	DW5806	DWA54058	DWA54058
7434SD1-PWR	7434SD1USA-PWR	5/8" x 6"	4"	25	75	-	DW5446	DW5806	DWA54058	DWA54058
7436SD1-PWR	7436SD1USA-PWR*	5/8" x 7"	5"	25	75	-	DW5447	DW5806	DWA54058	DWA54058
7438SD1-PWR	7438SD1USA-PWR*	5/8" x 8-1/2"	6-1/2"	25	50	-	DW5447	DW5809	DWA54058	DWA54058
7439SD1-PWR	-	5/8" x 10"	8"	25	75	-	DW5447	DW5809	DWA54058	DWA54034
7440SD1-PWR	7440SD1USA-PWR*	3/4" x 4-1/4"	1-3/4"	20	60	-	DW5453	DW5810	DWA54034	DWA54034
7441SD1-PWR	7441SD1USA-PWR*	3/4" x 4-3/4"	2-1/4"	20	60	-	DW5453	DW5810	DWA54034	DWA54034
7442SD1-PWR	7442SD1USA-PWR	3/4" x 5-1/2"	3"	20	60	-	DW5453	DW5810	DWA54034	DWA54034
7444SD1-PWR	7444SD1USA-PWR	3/4" x 6-1/4"	3-3/4"	20	60	-	DW5455	DW5810	DWA54034	DWA54034
7446SD1-PWR	7446SD1USA-PWR	3/4" x 7"	4-1/2"	20	60	-	DW5455	DW5810	DWA54034	DWA54034
7448SD1-PWR	7448SD1USA-PWR*	3/4" x 8-1/2"	6"	10	40	-	DW5455	DW5812	DWA54034	DWA54034
7449SD1-PWR	-	3/4" x 10"	7-1/2"	10	30	-	DW5455	DW5812	DWA54034	DWA54034
7451SD1-PWR	-	3/4" x 12"	9-1/2"	10	30	-	DW5456	DW5812	DWA54034	DWA54034
7450SD1-PWR	-	7/8" x 6"	2-3/4"	10	20	-	-	DW5815	-	DWA54078
7452SD1-PWR	-	7/8" x 8"	4-3/4"	10	40	-	-	DW5815	-	DWA54078
7454SD1-PWR	-	7/8" x 10"	6-3/4"	10	30	-	-	DW5816	-	DWA54078
7461SD1-PWR	-	1" x 6"	2-3/8"	10	30	-	-	DW5818	-	DWA58001
7463SD1-PWR	-	1" x 9"	5-3/8"	10	30	-	-	DW5819	-	DWA58001
7465SD1-PWR	-	1" x 12"	8-3/8"	5	15	-	-	DW5819	-	DWA58001
7473SD1-PWR	-	1-1/4" x 9"	4-3/4"	5	15	-	-	DW5820	-	-
7475SD1-PWR	-	1-1/4" x 12"	7-3/4"	5	15	-	-	DW5825	-	-

Shaded catalog numbers denote sizes which are less than the minimum standard anchor length for strength design. Anchors not long enough to meet the minimum nominal embedments published for strength design are outside the scope of ICC-ES ESR-2818.

* Denotes special order. Minimum quantities apply. Contact DeWALT for details.

The published size includes the diameter and the overall length of the anchor. Allow for fixture thickness (as applicable) plus one anchor diameter for the nut and washer thickness when selecting a length.

All anchors are packaged with nuts and washers.

Hollow drill bits must be used with a dust extraction vacuum (e.g. Cat. No. DW010, DW012, DW015, DCV585).

Tie Wire Power-Stud+ SD1 (Carbon Steel Body and Expansion clip)

Cat. No.	Anchor Size	Eyelet Hole Size	Pack Qty.	Carton Qty.
7409SD1-PWR	1/4" x 2"	9/32"	100	500



The Tie Wire Power-Stud+ is not listed in ICC-ES ESR-2818.

The minimum nominal embedment is 1-1/8", see Performance Data (ASD) in normal weight concrete..